

SITE SPECIFIC SOILS LEGEND

SYMBOL	SLOPES	SOIL TAXONOMIC NAME	HYDROLOGIC SOIL GROUP
12	B,C,D,E	HINCKLEY	A
26	B,D	WINDSOR	A
29	B,C,D,E	WOODBRIDGE	C
40	B,C	CHATFIELD HOLLIS COMPLEX	C/D
43	B,C,D,E	CANTON (VERY STONY)	B
67	B,C,D,E	PAXTON (VERY STONY)	C
68	B,C	SUTTON	B
115	A	SCARBORO	D
118	B,C,D,E	SUDBURY	B
313	B,C,D,E	DEERFIELD	B
400	A,B,C,D	UDORTHENTS (SANDY OR GRAVELLY)	A
496	A	NATCHAUG VARIANT	D
500	B	UDORTHENTS (LOAMY)	C
547	B	WALPOLE (VERY STONY)	C
900	A	ENDOQUENTS (SANDY OR GRAVELLY)	A

SLOPE: A = 0-3% B = 3-8% C = 8-15% D = 15-25% E = 25-50% F = 50%+
 DENOMINATOR: /VP = VERY POORLY DRAINED /P = POORLY DRAINED
 /SWP = SOMEWHAT POORLY DRAINED /MW = MODERATELY WELL DRAINED

WETLAND NOTE:

- WETLANDS WERE DELINEATED BY JOHN P. HAYES, CWS, IN THE SUMMER OF 2022 USING THE FOLLOWING CRITERIA:
- USACE, REGIONAL SUPPLEMENT TO THE CORPS OF ENGINEERS WETLAND DELINEATION MANUAL: NORTHCENTRAL AND NORTHEAST REGION, VERSION 2.0. U.S. ARMY ENGINEER RESEARCH AND DEVELOPMENT CENTER, 2012. WICKSBURG, MS.
 - USACE, CORPS OF ENGINEERS WETLANDS DELINEATION MANUAL, ENVIRONMENTAL LABORATORY, 1987. WICKSBURG, MS.
 - UNITED STATES DEPARTMENT OF AGRICULTURE, NATURAL RESOURCES CONSERVATION SERVICE, 2018. FIELD INDICATORS OF HYDRIC SOILS IN THE UNITED STATES, VERSION 8.2. L.M. VASILAS, G.W. HURT, AND J.F. BERKOWITZ (EDS.). USDA, NRCS, IN COOPERATION WITH THE NATIONAL TECHNICAL COMMITTEE FOR HYDRIC SOILS.
 - NEW ENGLAND HYDRIC SOIL TECHNICAL COMMITTEE, FIELD INDICATORS FOR IDENTIFYING HYDRIC SOILS IN NEW ENGLAND, VERSION 4. NEW ENGLAND INTERSTATE WATER POLLUTION CONTROL COMMISSION, 2019. LOWELL, MA.
 - U.S. ARMY CORPS OF ENGINEERS 2019. NATIONAL WETLAND PLANT LIST, VERSION 3.3. [HTTP://WETLAND-PLANTS.USACE.ARMY.MIL/](http://wetland-plants.usace.army.mil/)



JOHN P. HAYES, CWS

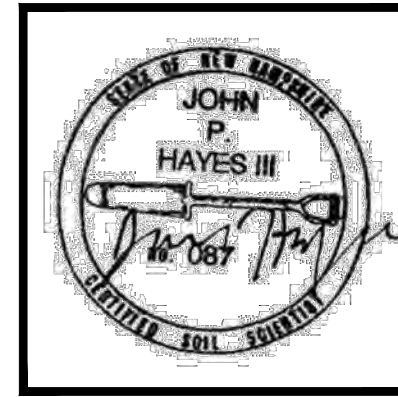

JOHN P. HAYES, CSS

LEGEND:

- EXISTING CONTOUR MINOR
- EXISTING CONTOUR MAJOR
- STONE WALL
- WETLAND LINE
- LIMIT OF SITE SPECIFIC SOILS SURVEY
- SOIL LINE
- SOIL SERIES
- NRCS SOIL LINE
- NRCS SOIL LABEL
- LIMIT OF WATERSHED
- TIME OF CONCENTRATION PATH
- FLOW REACH
- MATCH LINE
- ROCKINGHAM COUNTY REGISTRY OF DEEDS
- TYPICAL FOUND TO BE REMOVED

SYMBOLS LEGEND:

- SUBCATCHMENT AREA SYMBOL
- FLOW REACH SYMBOL
- POND DEVICE SYMBOL
- TIME OF CONCENTRATION SEGMENT

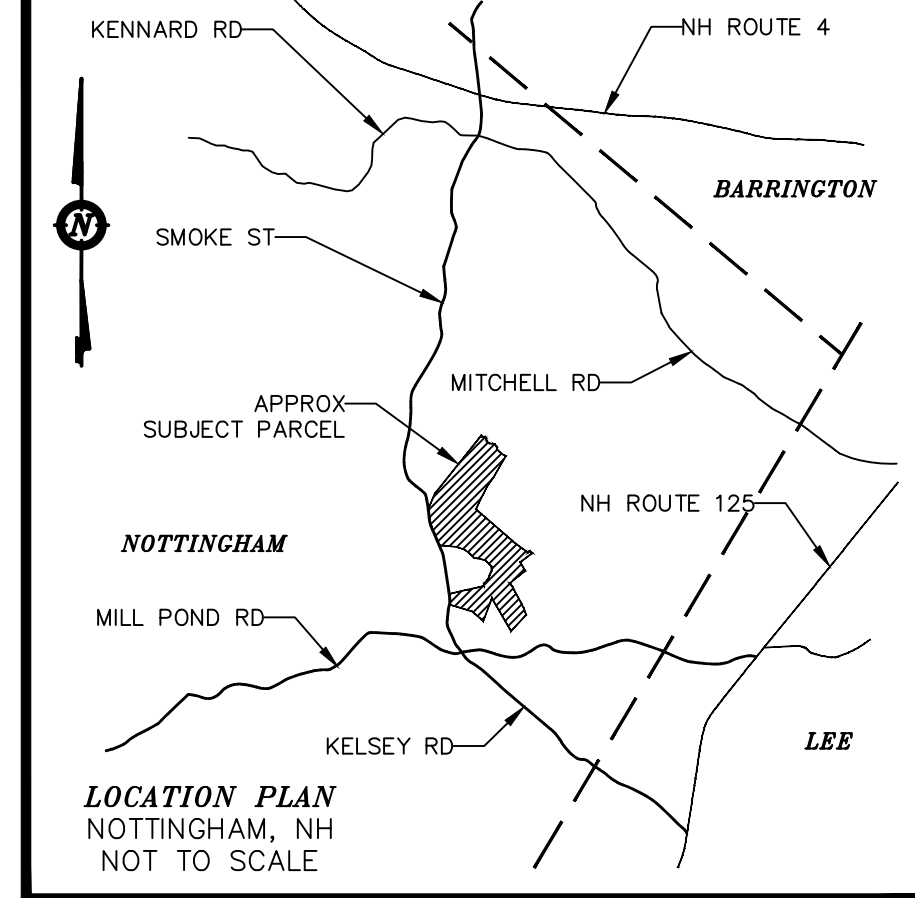

NOTES:

- OWNER: FREDERICK FERNALD, PO BOX 1805, WOLFEBORO, NH 03894
- APPLICANT: OWL RIDGE BUILDERS, 104 RAYMOND ROAD, NOTTINGHAM, NH 03290
- TAX MAP 23, LOT 11
- LOT AREA: 4,477,048 Sq.Ft., 102.77 Ac.
- THE INTENT OF THIS PLAN IS TO SHOW THE EXISTING DRAINAGE CONDITIONS OF TAX MAP 23, LOT 11 AS OF THE DATE OF THE SURVEY.
- HYDROCAD USES A SERIES OF NODE SUFFIXES FOR NUMBERING PURPOSES (S=SUBCATCHMENT, P=POND DEVICE, R=REACH), TO SIMPLIFY ANNOTATION THESE SUFFIXES ARE LEFT OFF THE WATERSHED PLANS AND NODE TYPE IS DENOTED BY THE SYMBOL SHAPE ACCORDING TO THE DISPLAYED LEGEND WHICH COINCIDES WITH HYDROCAD GRAPHICS.

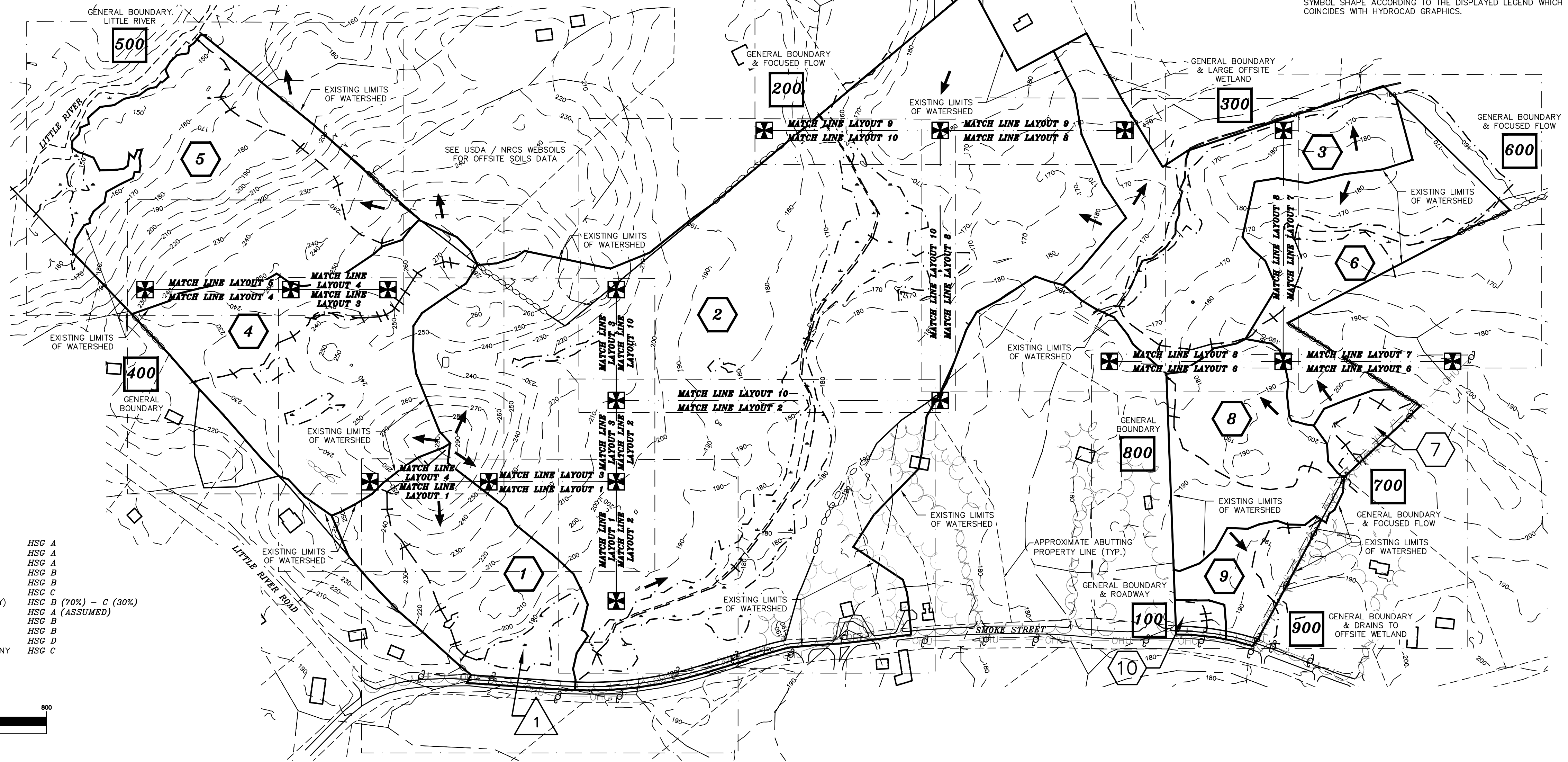
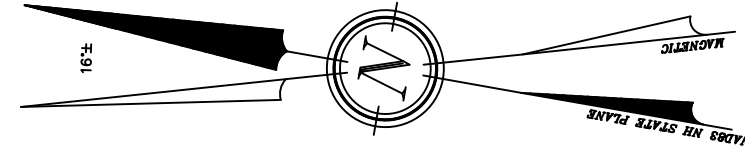

NRCS SOILS DATA:

- 12A ~ HINCKLEY LOAMY SAND (0-3% SLOPES) HSG A
- 12B ~ HINCKLEY LOAMY SAND (3-8% SLOPES) HSG A
- 12C ~ HINCKLEY LOAMY SAND (8-15% SLOPES) HSG A
- 43C ~ CANTON FINE SANDY LOAM (8-15% SLOPES) HSG B
- 43D ~ CANTON FINE SANDY LOAM (15-25% SLOPES) HSG B
- 67D ~ PAXTON FINE SANDY LOAM (15-25% SLOPES) HSG C
- 140C ~ CHATFIELD-HOLLIS-CANTON COMPLEX (8-15% SLOPES, ROCKY) HSG B (70%) - C (30%)
- 298 ~ PITS, SAND AND GRAVEL HSG A (ASSUMED)
- 299 ~ UDORTHENTS, SMOOTHED HSG B
- 313B ~ DEERFIELD LOAMY FINE SAND (3-8% SLOPES) HSG B
- 395 ~ SWANSEA MUCKY PEAT (0-2% SLOPES) HSG D
- 547B ~ WALPOLE VERY FINE SANDY LOAM (3-8% SLOPES) VERY STONY HSG C

SEE USDA / NRCS WEBSOILS FOR OFFSITE SOILS DATA

GRAPHIC SCALE

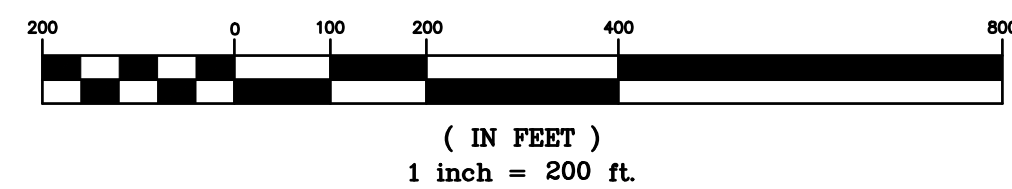

W-1 EXISTING CONDITION WATERSHED OVERVIEW PLAN

FOR OWL RIDGE BUILDERS
LAND OF FREDERICK FERNALD
SMOKE STREET & FORT HILL ROAD
NOTTINGHAM, N.H.
TAX MAP 23, LOT 11

BERRY SURVEYING & ENGINEERING
335 SECOND CROWN POINT ROAD
BARRINGTON, NH 03825 (603)332-2863
SCALE : 1 IN. EQUALS 200 FT.
DATE : FEBRUARY 15, 2023
FILE NO. : DB 2020 - 065

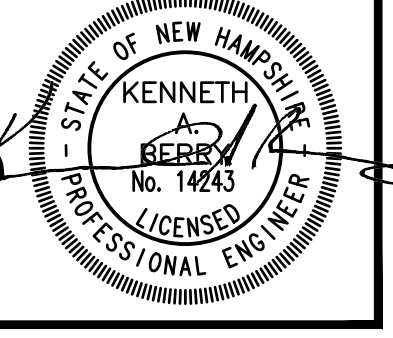

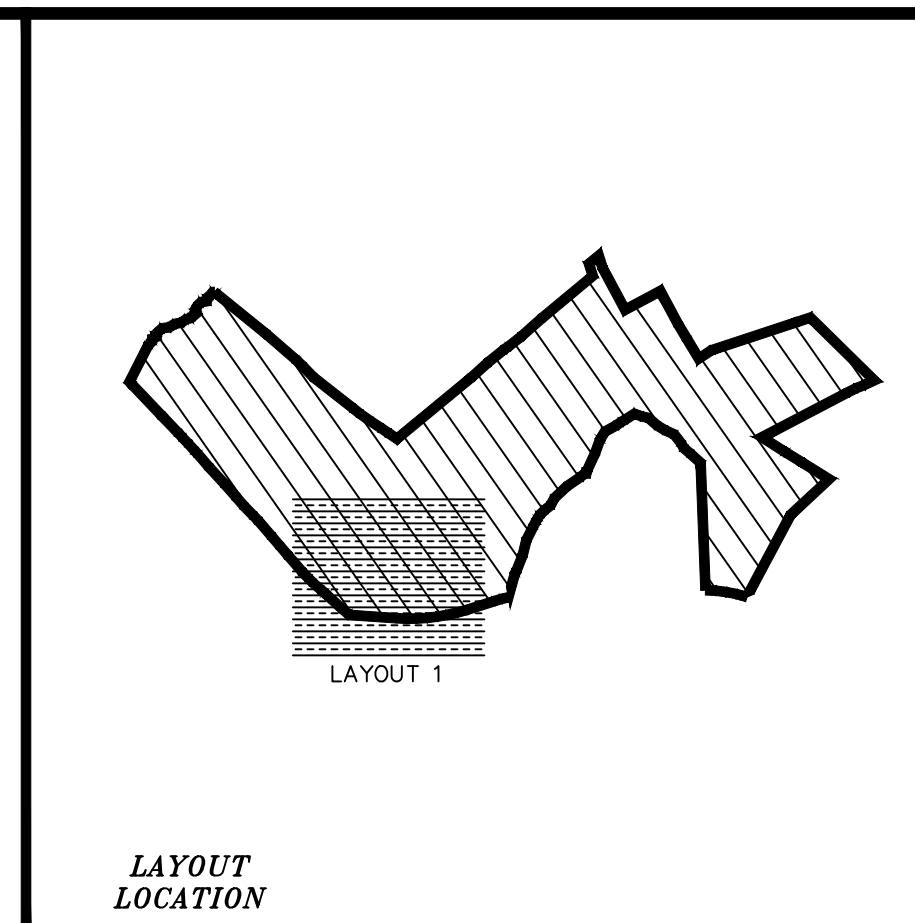
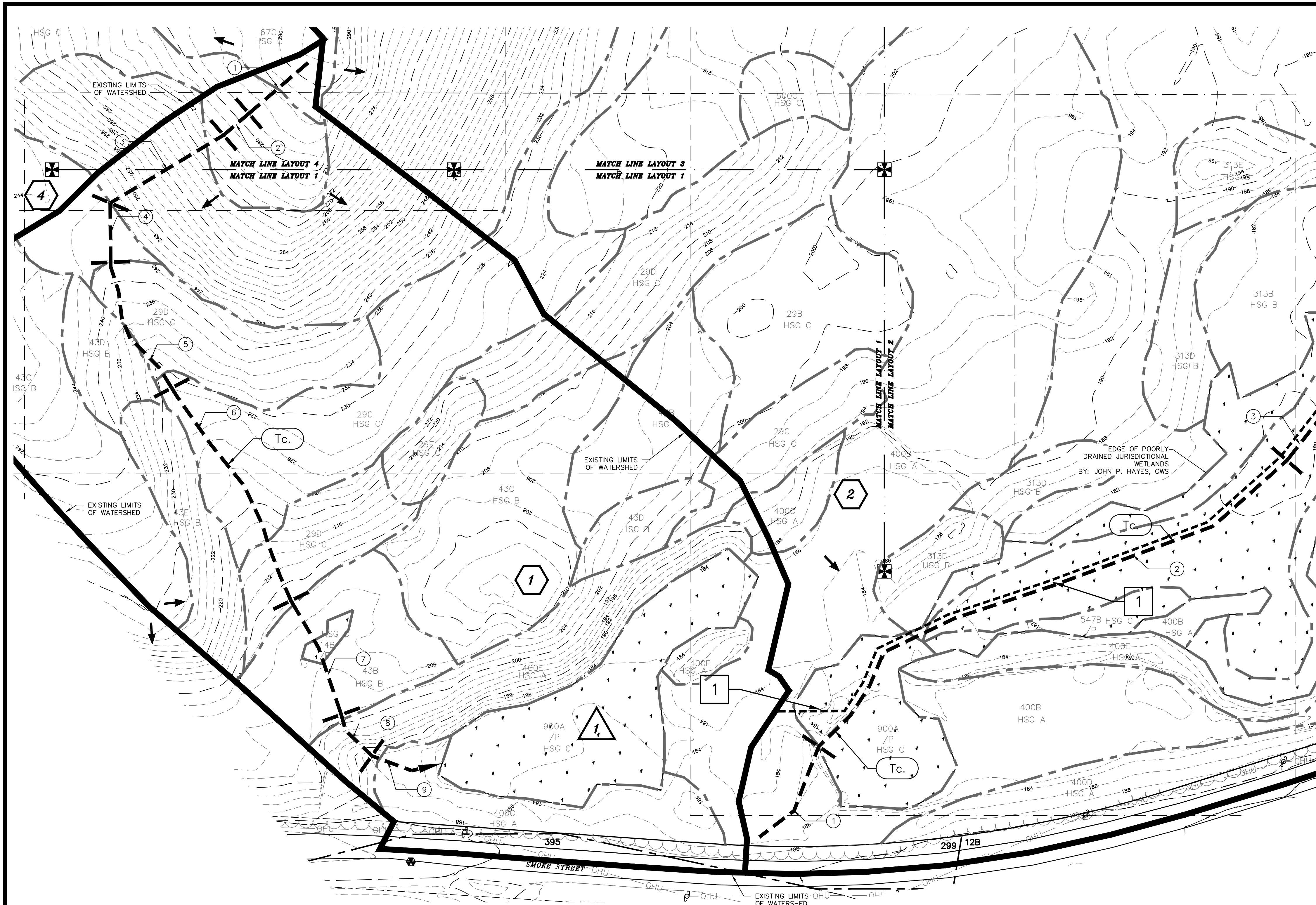

NOTES:

- 1.) OWNER: FREDERICK FERNALD
PO BOX 1805
WOLFEBORO, NH 03894
- 1A.) APPLICANT: OWL RIDGE BUILDERS
104 RAYMOND ROAD
NOTTINGHAM, NH 03290
- 2.) TAX MAP 23, LOT 11
- 3.) LOT AREA: 4,477,048 Sq.Ft., 102.77 Ac.
- 4.) THE INTENT OF THIS PLAN IS TO SHOW THE EXISTING DRAINAGE CONDITIONS OF TAX MAP 23, LOT 11 AS OF THE DATE OF THE SURVEY.
- 5.) HYDROCAD USES A SERIES OF NODE SUFFIXES FOR NUMBERING PURPOSES (S=SUBCATCHMENT, P=POND DEVICE, R=REACH), TO SIMPLIFY ANNOTATION THESE SUFFIXES ARE LEFT OFF THE WATERSHED PLANS AND NODE TYPE IS DENOTED BY THE SYMBOL SHAPE ACCORDING TO THE DISPLAYED LEGEND WHICH COINCIDES WITH HYDROCAD GRAPHICS.

LEGEND:

	EXISTING CONTOUR MINOR
	EXISTING CONTOUR MAJOR
	STONE WALL
	WETLAND LINE
	LIMIT OF SITE SPECIFIC SOILS SURVEY
	SOIL LINE
	SOIL SERIES
	NRCS SOIL LINE
	NRCS SOIL LABEL
	LIMIT OF WATERSHED
	TIME OF CONCENTRATION PATH
	FLOW REACH
	MATCH LINE
	ROCKINGHAM COUNTY REGISTRY OF DEEDS
	R.C.R.D.
	TYP. FOUND
	TBR TO BE REMOVED

SYMBOLS LEGEND:

	Subcatchment Area Symbol
	Flow Reach Symbol
	Pond Device Symbol
	Time of Concentration Segment

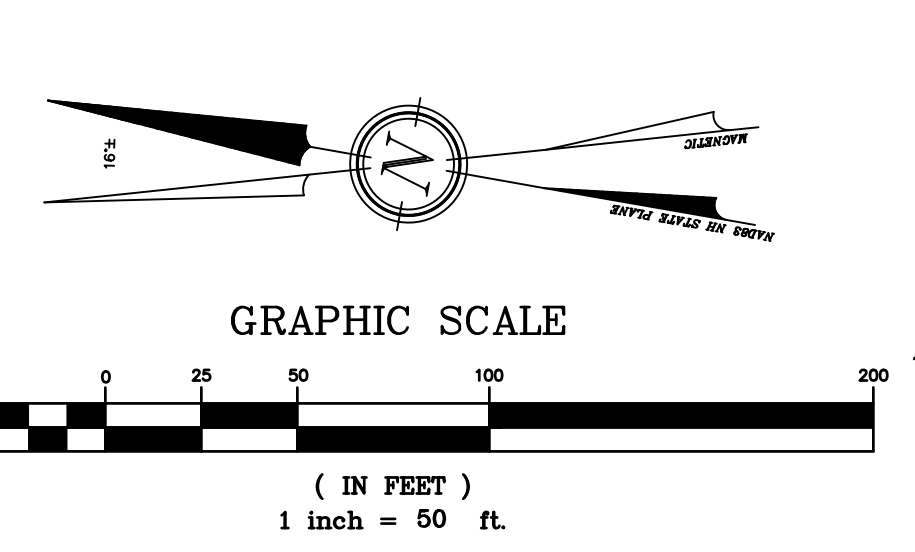

WETLAND NOTE:

WETLANDS WERE DELINEATED BY JOHN P. HAYES, CWS, IN THE SUMMER OF 2022 USING THE FOLLOWING CRITERIA:

1. USACE, REGIONAL SUPPLEMENT TO THE CORPS OF ENGINEERS WETLAND DELINEATION MANUAL: NORTHCENTRAL AND NORTHEAST REGION, VERSION 2.0. U.S. ARMY ENGINEER RESEARCH AND DEVELOPMENT CENTER, 2012. VICKSBURG, MS.
2. USACE, CORPS OF ENGINEERS WETLANDS DELINEATION MANUAL, ENVIRONMENTAL LABORATORY, 1987. VICKSBURG, MS.
3. UNITED STATES DEPARTMENT OF AGRICULTURE, NATURAL RESOURCES CONSERVATION SERVICE, 2018. FIELD INDICATORS OF HYDRIC SOILS IN THE UNITED STATES, VERSION 8.2. L.M. VASILAS, G.W. HURT, AND J.F. BERKOWITZ (EDS.), USDA, NRCS, IN COOPERATION WITH THE NATIONAL TECHNICAL COMMITTEE FOR HYDRIC SOILS.
4. NEW ENGLAND HYDRIC SOIL TECHNICAL COMMITTEE, FIELD INDICATORS FOR IDENTIFYING HYDRIC SOILS IN NEW ENGLAND, VERSION 4. NEW ENGLAND INTERSTATE WATER POLLUTION CONTROL COMMISSION, 2019. LOWELL, MA.
5. U.S. ARMY CORPS OF ENGINEERS 2019. NATIONAL WETLAND PLANT LIST, VERSION 3.3. [HTTP://WETLAND-PLANTS.USACE.ARMY.MIL/](http://wetland-plants.usace.army.mil/)

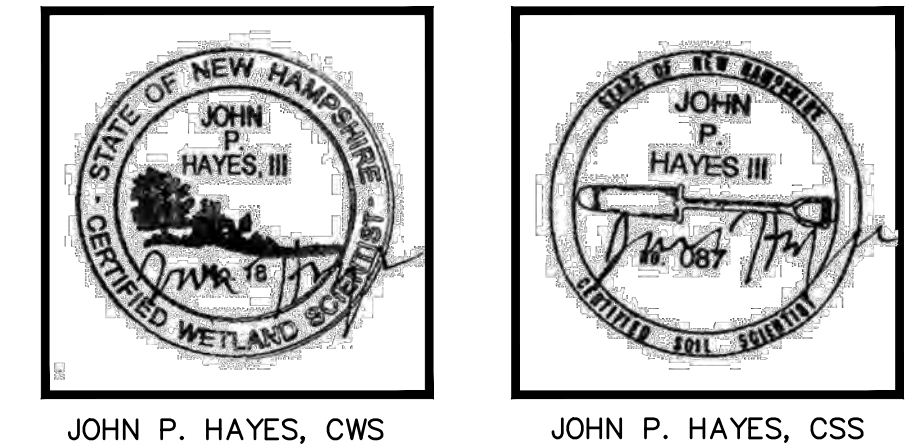

REVISION	DATE	DESCRIPTION

FOR
 OWL RIDGE BUILDERS
 LAND OF
 FREDERICK FERNALD
 SMOKE STREET & FORT HILL ROAD
 NOTTINGHAM, N.H.
 TAX MAP 23, Lot 11

BERRY SURVEYING & ENGINEERING
 335 SECOND CROWN POINT ROAD
 BARRINGTON, NH 03825 (603)332-2863
 SCALE : 1 IN. EQUALS 50 FT.
 DATE : FEBRUARY 15, 2023
 FILE NO. : DB 2020 - 065

WETLAND NOTE:

WETLANDS WERE DELINEATED BY JOHN P. HAYES, CWS, IN THE SUMMER OF 2022 USING THE FOLLOWING CRITERIA:

1. USACE, REGIONAL SUPPLEMENT TO THE CORPS OF ENGINEERS WETLAND DELINEATION MANUAL: NORTHCENTRAL AND NORTHEAST REGION, VERSION 2.0. U.S. ARMY ENGINEER RESEARCH AND DEVELOPMENT CENTER, 2012, VICKSBURG, MS.
2. USACE, CORPS OF ENGINEERS WETLANDS DELINEATION MANUAL, ENVIRONMENTAL LABORATORY, 1987, VICKSBURG, MS.
3. UNITED STATES DEPARTMENT OF AGRICULTURE, NATURAL RESOURCES CONSERVATION SERVICE, 2018, FIELD INDICATORS OF HYDRIC SOILS IN THE UNITED STATES, VERSION 8.2. L.M. VASILAS, G.W. HURT, AND J.F. BERKOWITZ (EDS.), USDA, NRCS, IN COOPERATION WITH THE NATIONAL TECHNICAL COMMITTEE FOR HYDRIC SOILS.
4. NEW ENGLAND HYDRIC SOIL TECHNICAL COMMITTEE, FIELD INDICATORS FOR IDENTIFYING HYDRIC SOILS IN NEW ENGLAND, VERSION 4. NEW ENGLAND INTERSTATE WATER POLLUTION CONTROL COMMISSION, 2019, LOWELL, MA.
5. U.S. ARMY CORPS OF ENGINEERS 2019, NATIONAL WETLAND PLANT LIST, VERSION 3.3. [HTTP://WETLAND-PLANTS.USACE.ARMY.MIL/](http://wetland-plants.usace.army.mil/)

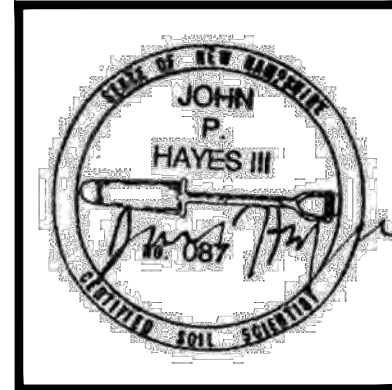

JOHN P. HAYES, CWS

JOHN P. HAYES, CSS

MATCH LINE LAYOUT 10
MATCH LINE LAYOUT 2

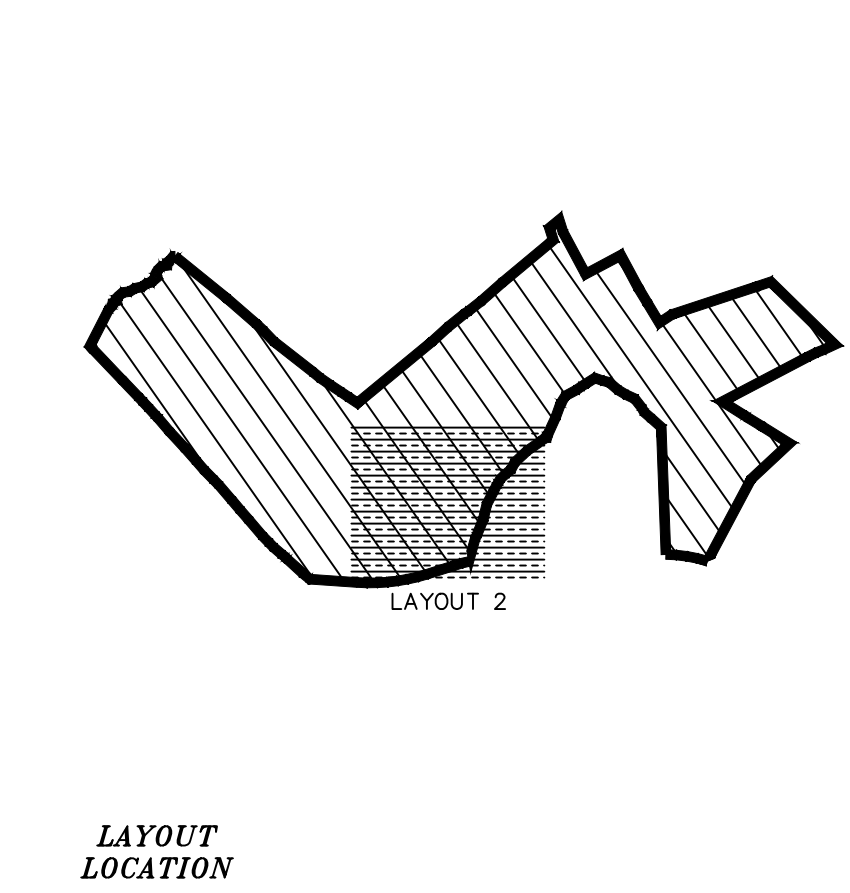
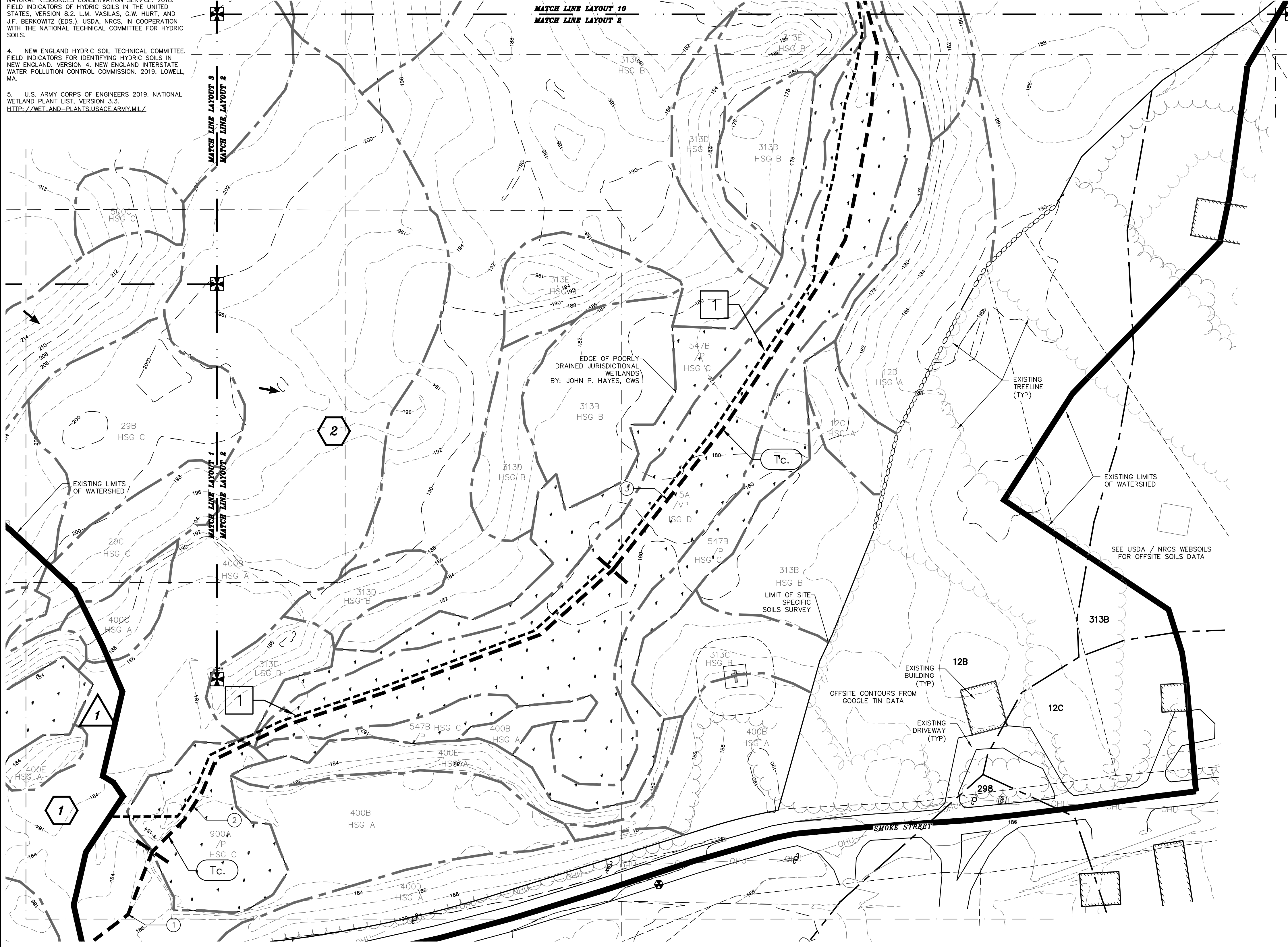

- NOTES:**
- 1.) OWNER: FREDERICK FERNALD
PO BOX 1805
WOLFEBORO, NH 03894
 - 1A.) APPLICANT: OWL RIDGE BUILDERS
104 RAYMOND ROAD
NOTTINGHAM, NH 03290
 - 2.) TAX MAP 23, LOT 11
 - 3.) LOT AREA: 4,477,048 Sq.Ft., 102.77 Ac.
 - 4.) THE INTENT OF THIS PLAN IS TO SHOW THE EXISTING DRAINAGE CONDITIONS OF TAX MAP 23, LOT 11 AS OF THE DATE OF THE SURVEY.
 - 5.) HYDROCAD USES A SERIES OF NODE SUFFIXES FOR NUMBERING PURPOSES (S=SUBCATCHMENT, P=POND DEVICE, R=REACH), TO SIMPLIFY ANNOTATION THESE SUFFIXES ARE LEFT OFF THE WATERSHED PLANS AND NODE TYPE IS DENOTED BY THE SYMBOL SHAPE ACCORDING TO THE DISPLAYED LEGEND WHICH COINCIDES WITH HYDROCAD GRAPHICS.

LEGEND:

	EXISTING CONTOUR MINOR
	EXISTING CONTOUR MAJOR
	STONE WALL
	WETLAND LINE
	LIMIT OF SITE SPECIFIC SOILS SURVEY
	SOIL LINE
	NRCS SOIL LINE
	NRCS SOIL LABEL
	LIMIT OF WATERSHED
	TIME OF CONCENTRATION PATH
	FLOW REACH
	MATCH LINE
	ROCKINGHAM COUNTY REGISTRY OF DEEDS
	R.C.R.D.
	TYP.
	FND
	TBR
	TO BE REMOVED

SYMBOLS LEGEND:

	Subcatchment Area Symbol
	Flow Reach Symbol
	Pond Device Symbol
	Time of Concentration Segment

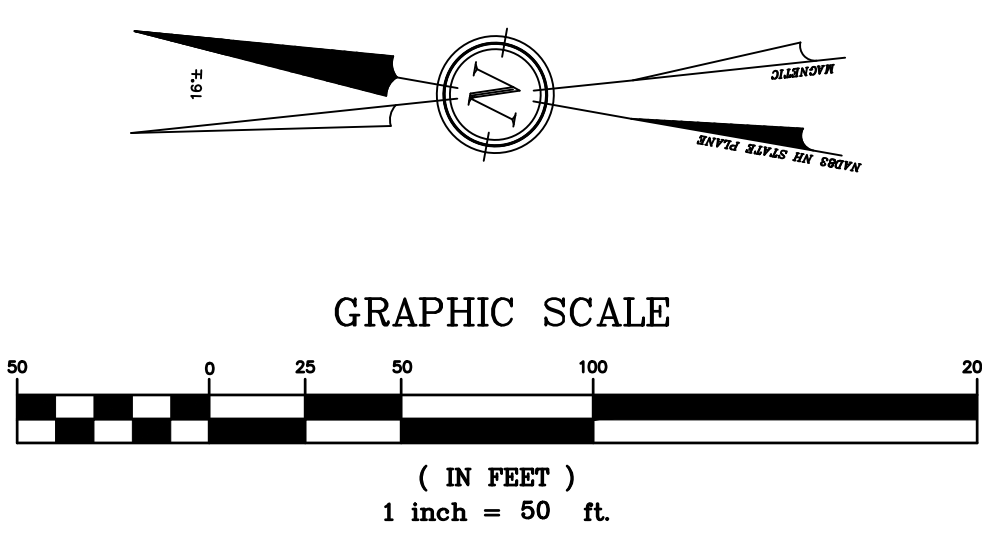

REVISION	DATE	DESCRIPTION

FOR
OWL RIDGE BUILDERS
LAND OF
FREDERICK FERNALD
SMOKE STREET & FORT HILL ROAD
NOTTINGHAM, N.H.
TAX MAP 23, Lot 11

BERRY SURVEYING & ENGINEERING
335 SECOND CROWN POINT ROAD
BARRINGTON, NH 03825 (603)332-2863
SCALE : 1 IN. EQUALS 50 FT.
DATE : FEBRUARY 15, 2023
FILE NO. : DB 2020 - 065

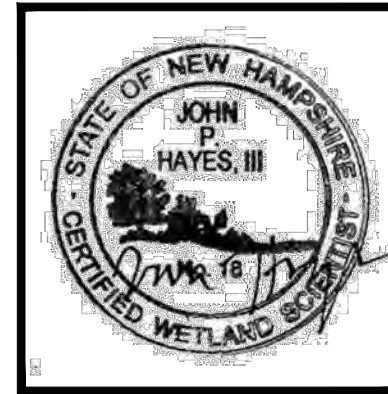

JOHN P. HAYES, CWS

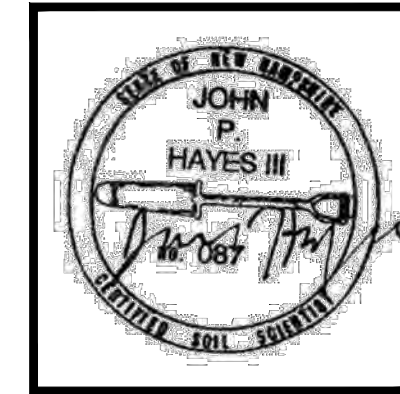

JOHN P. HAYES, CSS

WETLAND NOTE:

- WETLANDS WERE DELINEATED BY JOHN P. HAYES, CWS, IN THE SUMMER OF 2022 USING THE FOLLOWING CRITERIA:
1. USACE, REGIONAL SUPPLEMENT TO THE CORPS OF ENGINEERS WETLAND DELINEATION MANUAL: NORTH-CENTRAL AND NORTHEAST REGION, VERSION 2.0. U.S. ARMY ENGINEER RESEARCH AND DEVELOPMENT CENTER, 2012. VICKSBURG, MS.
 2. USACE, CORPS OF ENGINEERS WETLANDS DELINEATION MANUAL, ENVIRONMENTAL LABORATORY, 1987. VICKSBURG, MS.
 3. UNITED STATES DEPARTMENT OF AGRICULTURE, NATURAL RESOURCES CONSERVATION SERVICE, 2018. FIELD INDICATORS OF HYDRIC SOILS IN THE UNITED STATES, VERSION 8.2. L.M. VASILAS, G.W. HURT, AND J.F. BERKOWITZ (EDS.), USDA, NRCS, IN COOPERATION WITH THE NATIONAL TECHNICAL COMMITTEE FOR HYDRIC SOILS.
 4. NEW ENGLAND HYDRIC SOIL TECHNICAL COMMITTEE, FIELD INDICATORS FOR IDENTIFYING HYDRIC SOILS IN NEW ENGLAND, VERSION 4. NEW ENGLAND INTERSTATE WATER POLLUTION CONTROL COMMISSION, 2019. LOWELL, MA.
 5. U.S. ARMY CORPS OF ENGINEERS 2019, NATIONAL WETLAND PLANT LIST, VERSION 3.3. [HTTP://WETLAND-PLANTS.USACE.ARMY.MIL/](http://wetland-plants.usace.army.mil/)

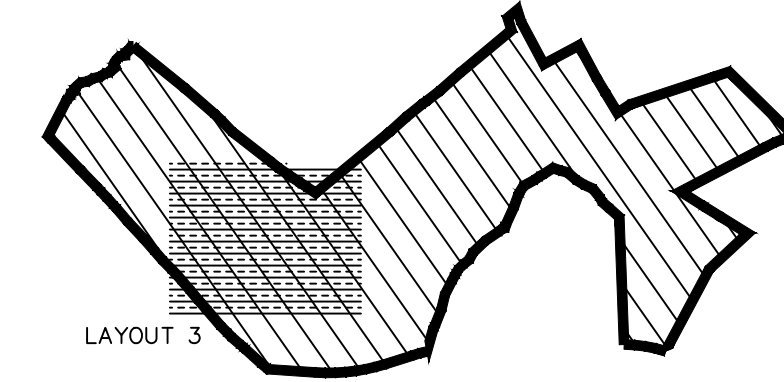

LAYOUT 3
LAYOUT LOCATION

NOTES:

- 1.) OWNER: FREDERICK FERNALD
PO BOX 1805
WOLFEBORO, NH 03894
- 1A.) APPLICANT: OWL RIDGE BUILDERS
104 RAYMOND ROAD
NOTTINGHAM, NH 03290
- 2.) TAX MAP 23, LOT 11
- 3.) LOT AREA: 4,477,048 Sq.Ft., 102.77 Ac.
- 4.) THE INTENT OF THIS PLAN IS TO SHOW THE EXISTING DRAINAGE CONDITIONS OF TAX MAP 23, LOT 11 AS OF THE DATE OF THE SURVEY.
- 5.) HYDROCAD USES A SERIES OF NODE SUFFIXES FOR NUMBERING PURPOSES (S=SUBCATCHMENT, P=POND DEVICE, R=REACH), TO SIMPLIFY ANNOTATION THESE SUFFIXES ARE LEFT OFF THE WATERSHED PLANS AND NODE TYPE IS DENOTED BY THE SYMBOL SHAPE ACCORDING TO THE DISPLAYED LEGEND WHICH COINCIDES WITH HYDROCAD GRAPHICS.

LEGEND:

- EXISTING CONTOUR MINOR
- EXISTING CONTOUR MAJOR
- STONE WALL
- WETLAND LINE
- LIMIT OF SITE SPECIFIC SOILS SURVEY
- 448A SOIL LINE
- 448B SOIL LINE
- NRCS SOIL LINE
- NRCS SOIL LABEL
- LIMIT OF WATERSHED
- TIME OF CONCENTRATION PATH
- FLOW REACH
- MATCH LINE
- ROCKINGHAM COUNTY REGISTRY OF DEEDS
- R.C.R.D. TYP. FND TBR TO BE REMOVED

SYMBOLS LEGEND:

- Subcatchment Area Symbol (Hexagon with #)
- Flow Reach Symbol (Square with #)
- Pond Device Symbol (Triangle with #)
- Time of Concentration Segment (Circle with #)

GRAPHIC SCALE

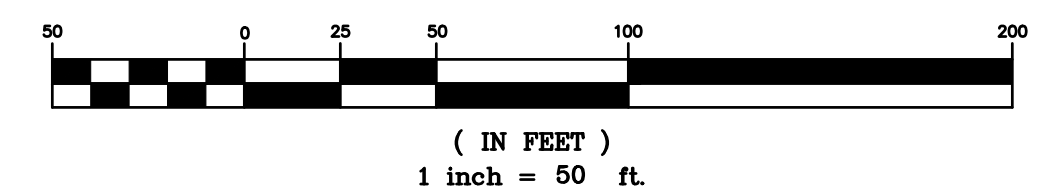

(IN FEET)
1 inch = 50 ft.

REVISION	DATE	DESCRIPTION

FOR
OWL RIDGE BUILDERS
LAND OF
FREDERICK FERNALD
SMOKE STREET & FORT HILL ROAD
NOTTINGHAM, N.H.
TAX MAP 23, Lot 11

BERRY SURVEYING & ENGINEERING
335 SECOND CROWN POINT ROAD
BARRINGTON, NH 03825 (603)332-2863
SCALE : 1 IN. EQUALS 50 FT.
DATE : FEBRUARY 15, 2023
FILE NO. : DB 2020 - 065

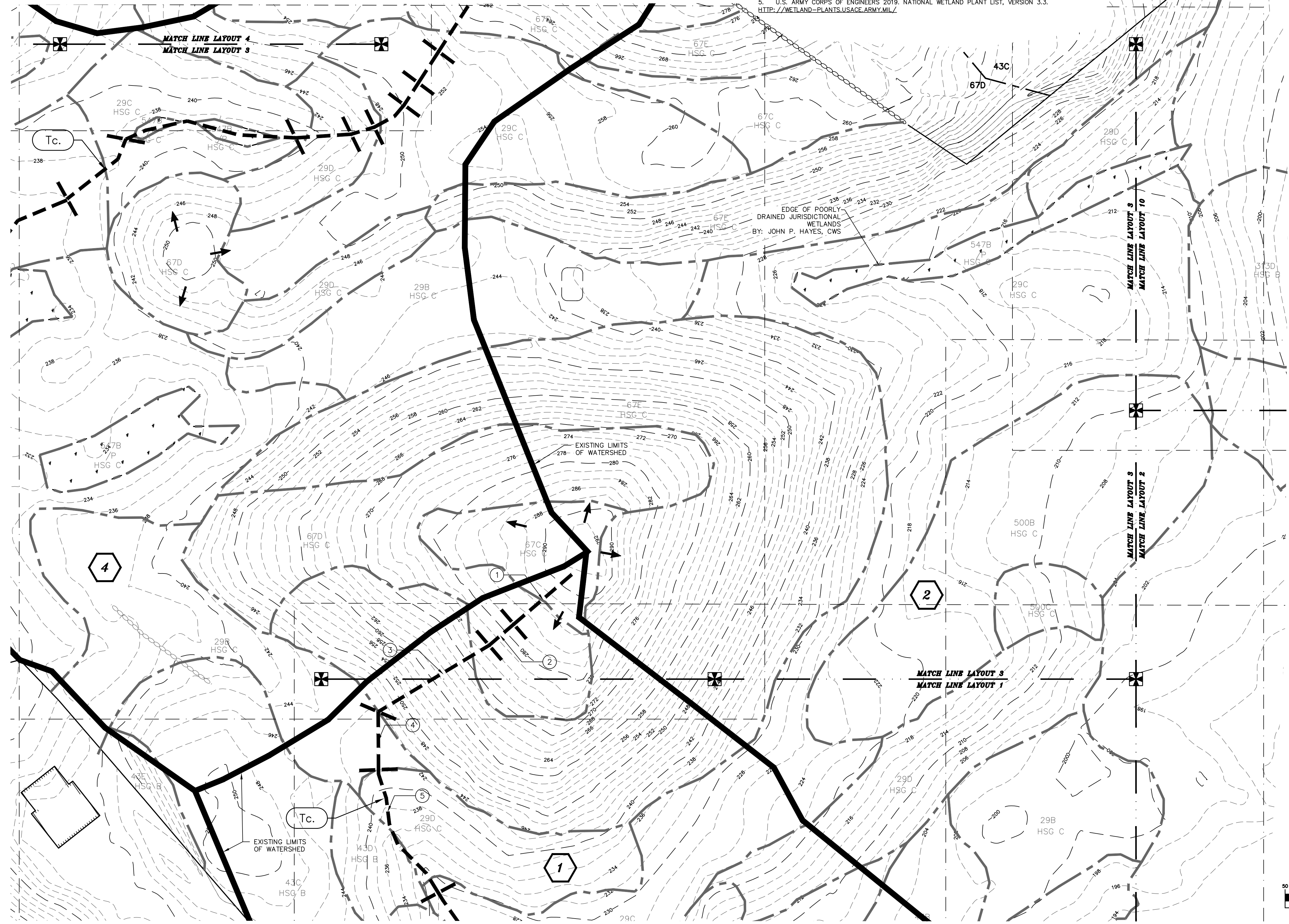
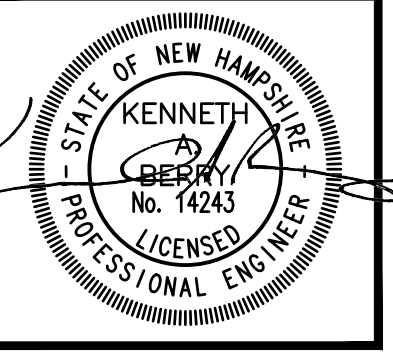

WETLAND NOTE:

WETLANDS WERE DELINEATED BY JOHN P. HAYES, CWS, IN THE SUMMER OF 2022 USING THE FOLLOWING CRITERIA:

1. USACE, REGIONAL SUPPLEMENT TO THE CORPS OF ENGINEERS WETLAND DELINEATION MANUAL: NORTHCENTRAL AND NORTHEAST REGION, VERSION 2.0. U.S. ARMY ENGINEER RESEARCH AND DEVELOPMENT CENTER. 2012. VICKSBURG, MS.
2. USACE, CORPS OF ENGINEERS WETLANDS DELINEATION MANUAL, ENVIRONMENTAL LABORATORY. 1987. VICKSBURG, MS.
3. UNITED STATES DEPARTMENT OF AGRICULTURE, NATURAL RESOURCES CONSERVATION SERVICE. 2018. FIELD INDICATORS OF HYDRIC SOILS IN THE UNITED STATES, VERSION 8.2. L.M. VASILEAS, G.W. HURT, AND J.F. BERKOWITZ (EDS.). USDA, NRCS, IN COOPERATION WITH THE NATIONAL TECHNICAL COMMITTEE FOR HYDRIC SOILS.
4. NEW ENGLAND HYDRIC SOIL TECHNICAL COMMITTEE. FIELD INDICATORS FOR IDENTIFYING HYDRIC SOILS IN NEW ENGLAND, VERSION 4. NEW ENGLAND INTERSTATE WATER POLLUTION CONTROL COMMISSION. 2019. LOWELL, MA.
5. U.S. ARMY CORPS OF ENGINEERS 2019. NATIONAL WETLAND PLANT LIST, VERSION 3.3. [HTTP://WETLAND-PLANTS.USACE.ARMY.MIL/](http://wetland-plants.usace.army.mil/)

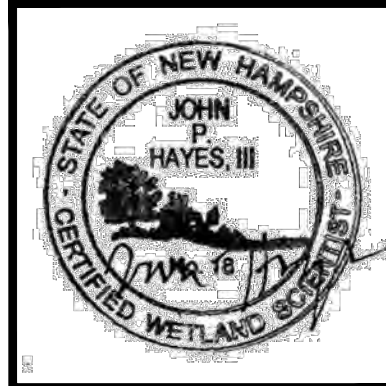

JOHN P. HAYES, CWS

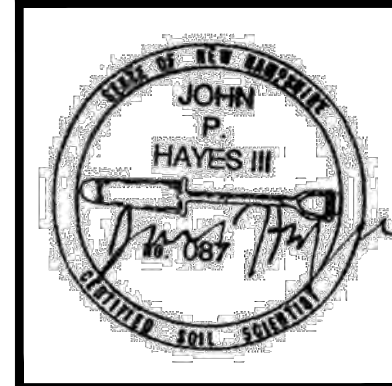

JOHN P. HAYES, CSS

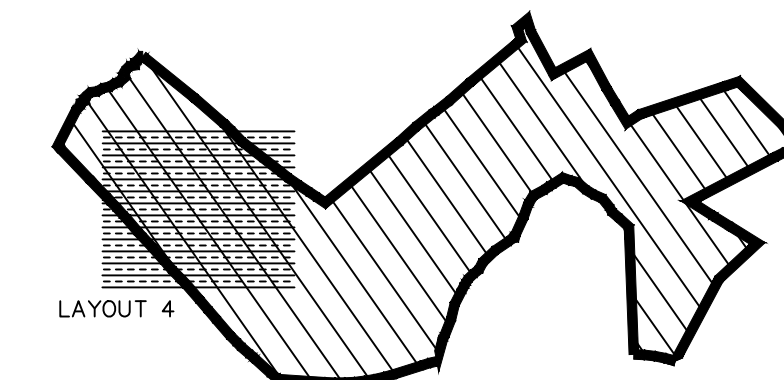
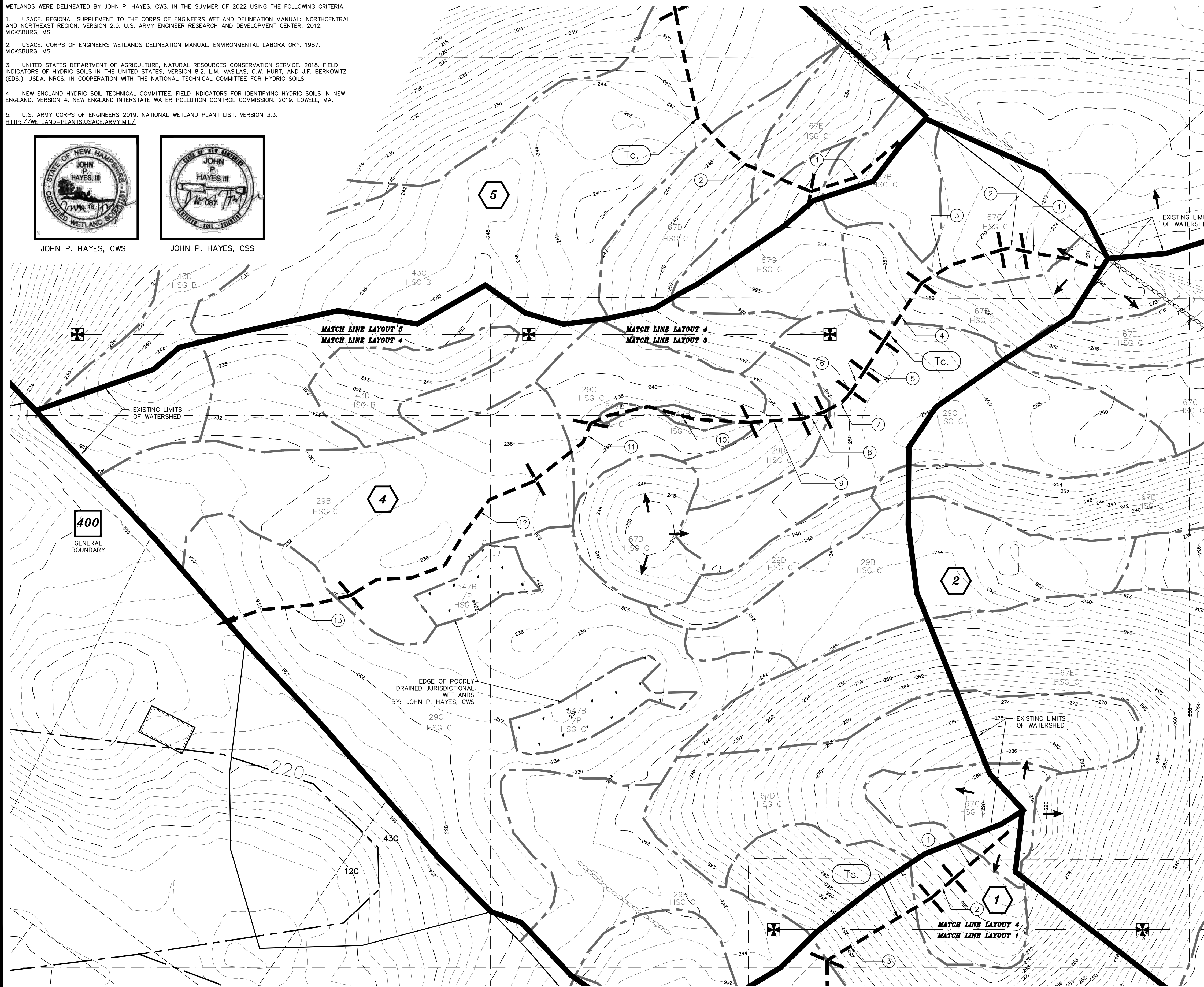

LAYOUT LOCATION

NOTES:

- 1.) OWNER: FREDERICK FERNALD
PO BOX 1805
WOLFEBORO, NH 03894
- 1A.) APPLICANT: OWL RIDGE BUILDERS
104 RAYMOND ROAD
NOTTINGHAM, NH 03290
- 2.) TAX MAP 23, LOT 11
- 3.) LOT AREA: 4,477,048 Sq.Ft., 102.77 Ac.
- 4.) THE INTENT OF THIS PLAN IS TO SHOW THE EXISTING DRAINAGE CONDITIONS OF TAX MAP 23, LOT 11 AS OF THE DATE OF THE SURVEY.
- 5.) HYDROCAD USES A SERIES OF NODE SUFFIXES FOR NUMBERING PURPOSES (S=SUBCATCHMENT, P=POND DEVICE, R=REACH), TO SIMPLIFY ANNOTATION THESE SUFFIXES ARE LEFT OFF THE WATERSHED PLANS AND NODE TYPE IS DENOTED BY THE SYMBOL SHAPE ACCORDING TO THE DISPLAYED LEGEND WHICH COINCIDES WITH HYDROCAD GRAPHICS.

LEGEND:

- EXISTING CONTOUR MINOR
- EXISTING CONTOUR MAJOR
- STONE WALL
- WETLAND LINE
- LIMIT OF SITE SPECIFIC SOILS SURVEY
- SOIL LINE
- SOIL SERIES
- NRCS SOIL LINE
- NRCS SOIL LABEL
- LIMIT OF WATERSHED
- TIME OF CONCENTRATION PATH
- FLOW REACH
- MATCH LINE
- ROCKINGHAM COUNTY REGISTRY OF DEEDS
- TYPICAL
- FOUND
- TO BE REMOVED

SYMBOLS LEGEND:

- SUBCATCHMENT AREA SYMBOL
- FLOW REACH SYMBOL
- POND DEVICE SYMBOL
- TIME OF CONCENTRATION SEGMENT

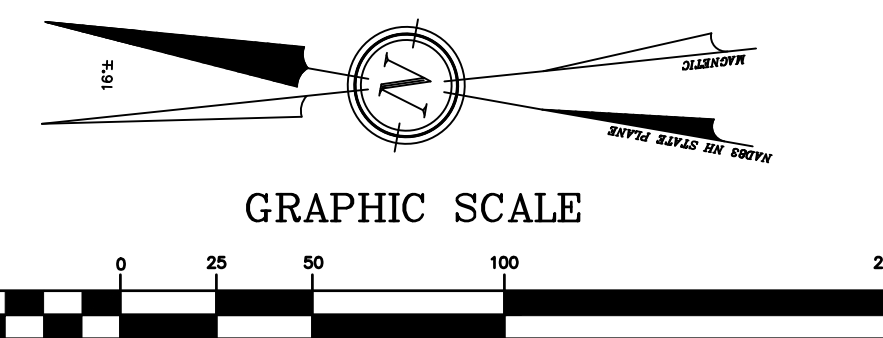

GRAPHIC SCALE
(IN FEET)
1 inch = 50 ft.

REVISION	DATE	DESCRIPTION

FOR
OWL RIDGE BUILDERS
LAND OF
FREDERICK FERNALD
SMOKE STREET & FORT HILL ROAD
NOTTINGHAM, N.H.
TAX MAP 23, Lot 11

BERRY SURVEYING & ENGINEERING
335 SECOND CROWN POINT ROAD
BARRINGTON, NH 03825 (603)332-2863
SCALE : 1 IN. EQUALS 50 FT.
DATE : FEBRUARY 15, 2023
FILE NO. : DB 2020 - 065

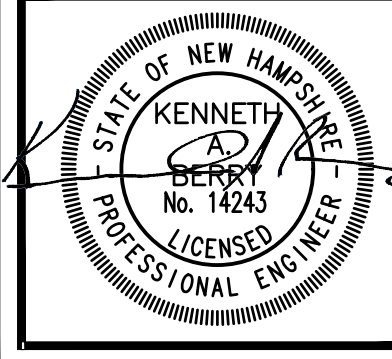

WETLAND NOTE:

- WETLANDS WERE DELINEATED BY JOHN P. HAYES, CWS, IN THE SUMMER OF 2022 USING THE FOLLOWING CRITERIA:
1. USACE, REGIONAL SUPPLEMENT TO THE CORPS OF ENGINEERS WETLAND DELINEATION MANUAL: NORTH-CENTRAL AND NORTHEAST REGION, VERSION 2.0. U.S. ARMY ENGINEER RESEARCH AND DEVELOPMENT CENTER, 2012. VICKSBURG, MS.
 2. USACE, CORPS OF ENGINEERS WETLANDS DELINEATION MANUAL, ENVIRONMENTAL LABORATORY, 1987. VICKSBURG, MS.
 3. UNITED STATES DEPARTMENT OF AGRICULTURE, NATURAL RESOURCES CONSERVATION SERVICE, 2018. FIELD INDICATORS OF HYDRIC SOILS IN THE UNITED STATES, VERSION 8.2. L.M. VASILAS, G.W. HURT, AND J.F. BERKOWITZ (EDS.). USDA, NRCS, IN COOPERATION WITH THE NATIONAL TECHNICAL COMMITTEE FOR HYDRIC SOILS.
 4. NEW ENGLAND HYDRIC SOIL TECHNICAL COMMITTEE, FIELD INDICATORS FOR IDENTIFYING HYDRIC SOILS IN NEW ENGLAND, VERSION 4. NEW ENGLAND INTERSTATE WATER POLLUTION CONTROL COMMISSION, 2019. LOWELL, MA.
 5. U.S. ARMY CORPS OF ENGINEERS 2019. NATIONAL WETLAND PLANT LIST, VERSION 3.3. [HTTP://WETLAND-PLANTS.USACE.ARMY.MIL/](http://wetland-plants.usace.army.mil/)

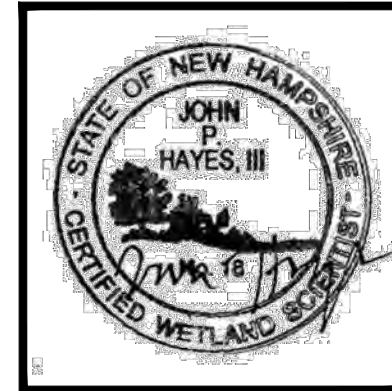

JOHN P. HAYES, CWS

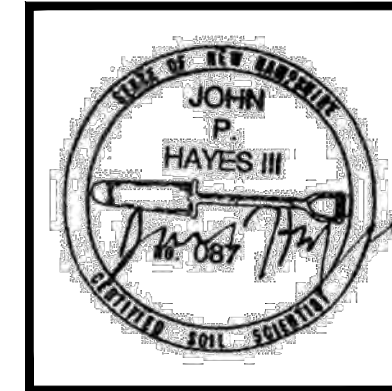

JOHN P. HAYES, CSS

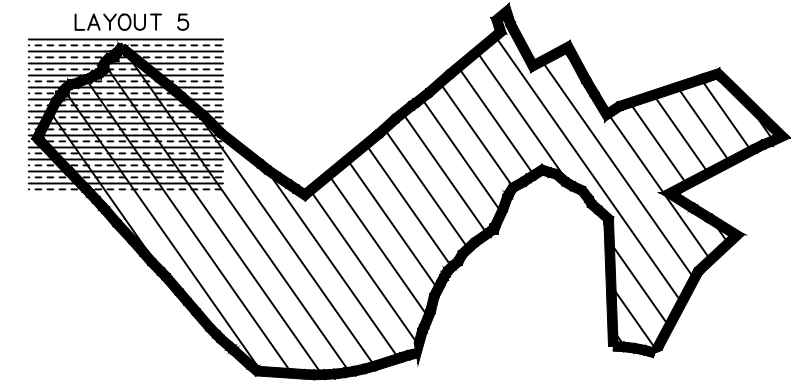

LAYOUT LOCATION

NOTES:

- 1.) OWNER: FREDERICK FERNALD
PO BOX 1805
WOLFEBORO, NH 03894
- 1A.) APPLICANT: OWL RIDGE BUILDERS
104 RAYMOND ROAD
NOTTINGHAM, NH 03290
- 2.) TAX MAP 23, LOT 11
- 3.) LOT AREA: 4,477,048 Sq.Ft., 102.77 Ac.
- 4.) THE INTENT OF THIS PLAN IS TO SHOW THE EXISTING DRAINAGE CONDITIONS OF TAX MAP 23, LOT 11 AS OF THE DATE OF THE SURVEY.
- 5.) HYDROCAD USES A SERIES OF NODE SUFFIXES FOR NUMBERING PURPOSES (S=SUBCATCHMENT, P=POND DEVICE, R=REACH), TO SIMPLIFY ANNOTATION THESE SUFFIXES ARE LEFT OFF THE WATERSHED PLANS AND NODE TYPE IS DENOTED BY THE SYMBOL SHAPE ACCORDING TO THE DISPLAYED LEGEND WHICH COINCIDES WITH HYDROCAD GRAPHICS.

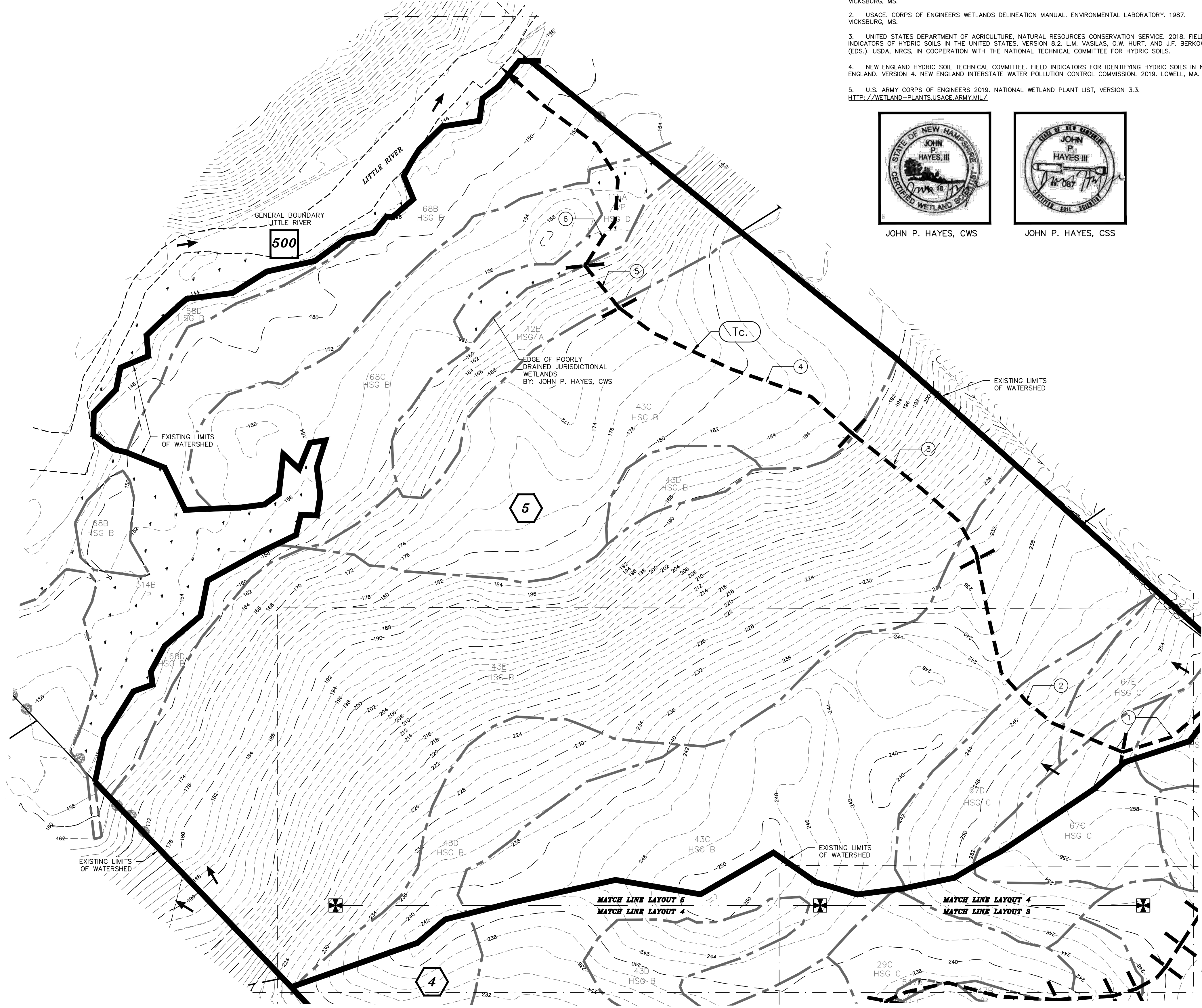

LEGEND:

	EXISTING CONTOUR MINOR
	EXISTING CONTOUR MAJOR
	STONE WALL
	WETLAND LINE
	LIMIT OF SITE SPECIFIC SOILS SURVEY
	SOIL LINE
	SOIL SERIES
	448A
	NRCS SOIL LINE
	NRCS SOIL LABEL
	LIMIT OF WATERSHED
	HfB
	TIME OF CONCENTRATION PATH
	FLOW REACH
	MATCH LINE
	R.C.R.D. ROCKINGHAM COUNTY REGISTRY OF DEEDS
	TYP. TYPICAL
	FND FOUND
	TBR TO BE REMOVED

SYMBOLS LEGEND:

	Subcatchment Area Symbol
	Flow Reach Symbol
	Pond Device Symbol
	Time of Concentration Segment
	Time of Concentration Segment

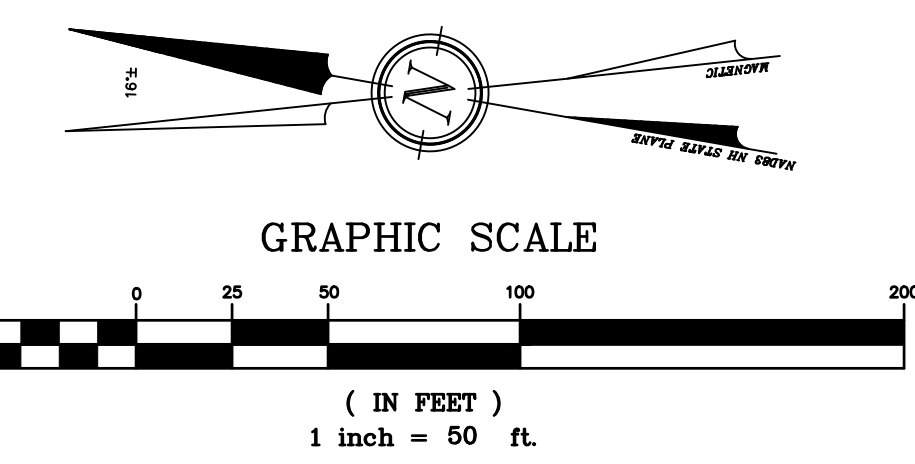

REVISION	DATE	DESCRIPTION

FOR
OWL RIDGE BUILDERS
LAND OF
FREDERICK FERNALD
SMOKE STREET & FORT HILL ROAD
NOTTINGHAM, N.H.
TAX MAP 23, Lot 11

BERRY SURVEYING & ENGINEERING
335 SECOND CROWN POINT ROAD
BARRINGTON, NH 03825 (603)332-2863
SCALE : 1 IN. EQUALS 50 FT.
DATE : FEBRUARY 15, 2023
FILE NO. : DB 2020 - 065

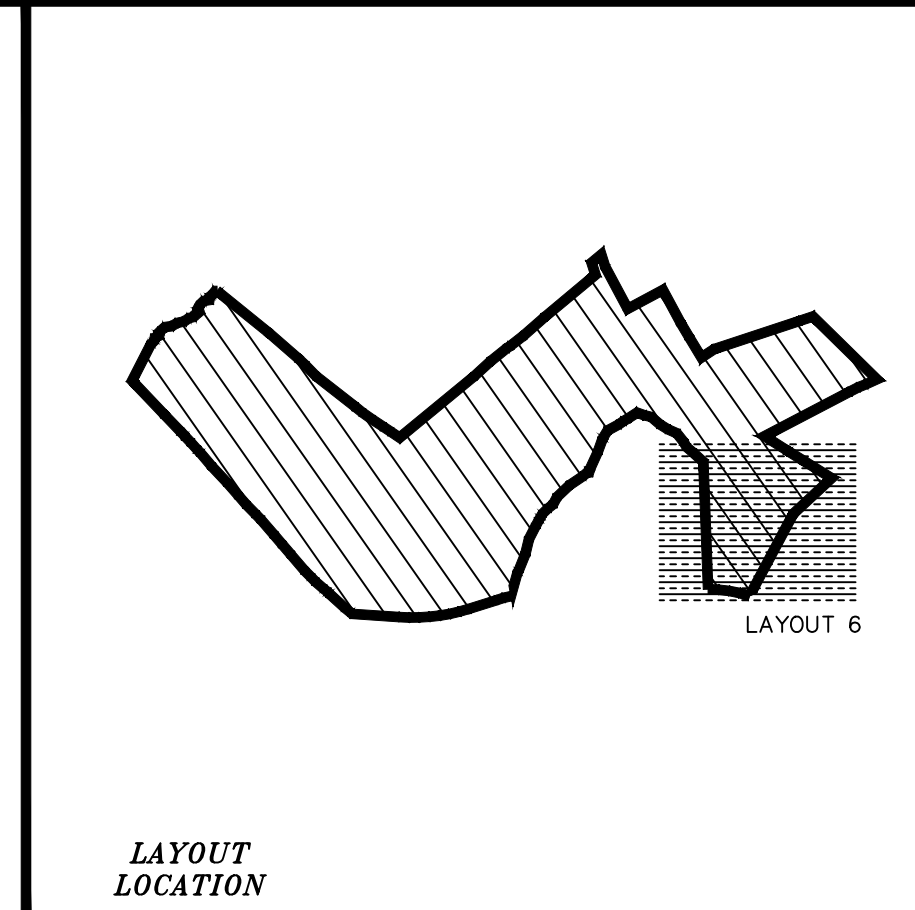
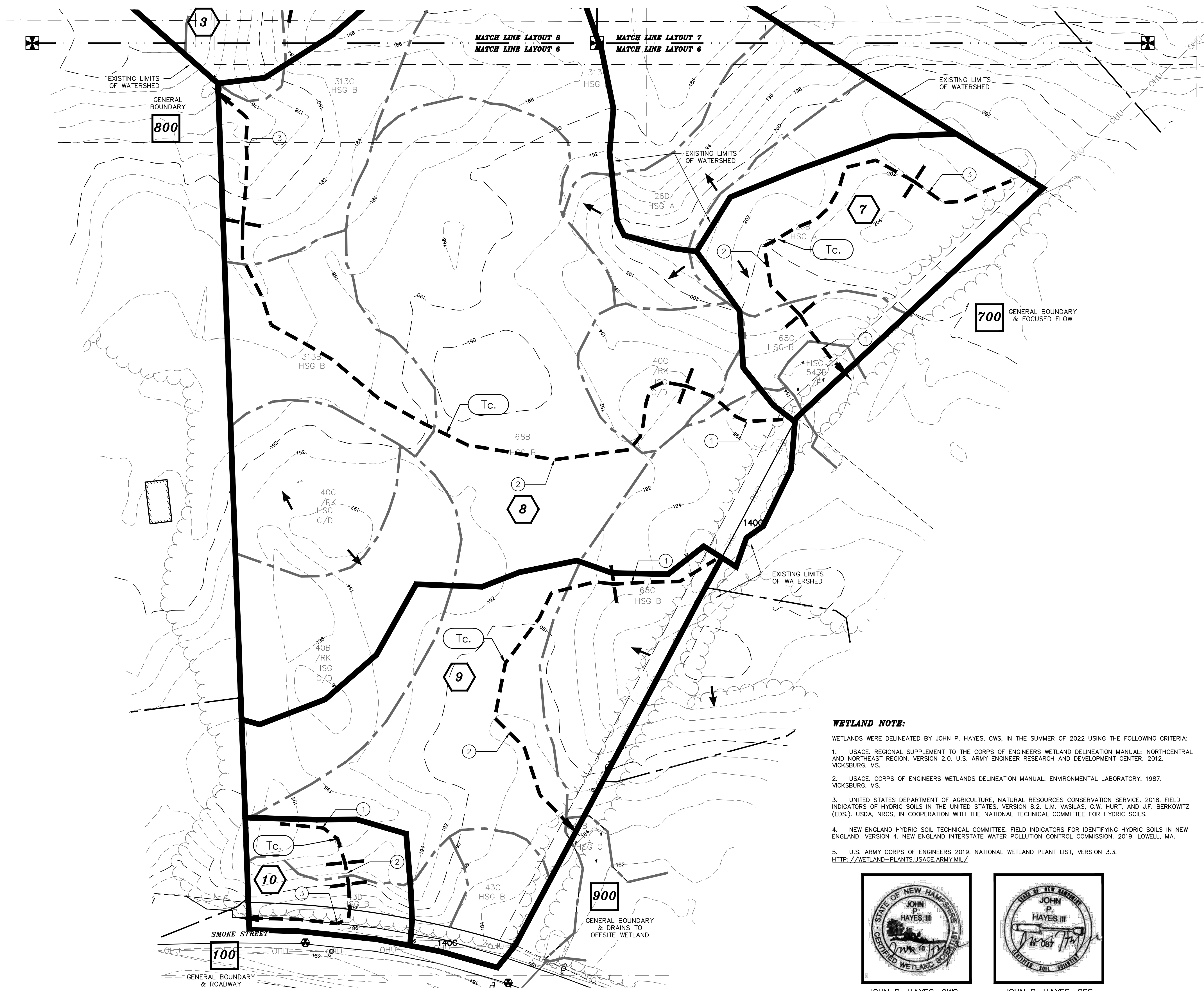

NOTES:

- 1.) OWNER: FREDERICK FERNALD
PO BOX 1805
WOLFEBORO, NH 03894
- 1A.) APPLICANT: OWL RIDGE BUILDERS
104 RAYMOND ROAD
NOTTINGHAM, NH 03290
- 2.) TAX MAP 23, LOT 11
- 3.) LOT AREA: 4,477,048 Sq.Ft., 102.77 Ac.
- 4.) THE INTENT OF THIS PLAN IS TO SHOW THE EXISTING DRAINAGE CONDITIONS OF TAX MAP 23, LOT 11 AS OF THE DATE OF THE SURVEY.
- 5.) HYDROCAD USES A SERIES OF NODE SUFFIXES FOR NUMBERING PURPOSES (S=SUBCATCHMENT, P=POND DEVICE, R=REACH), TO SIMPLIFY ANNOTATION THESE SUFFIXES ARE LEFT OFF THE WATERSHED PLANS AND NODE TYPE IS DENOTED BY THE SYMBOL SHAPE ACCORDING TO THE DISPLAYED LEGEND WHICH COINCIDES WITH HYDROCAD GRAPHICS.

LEGEND:

	EXISTING CONTOUR MINOR
	EXISTING CONTOUR MAJOR
	STONE WALL
	WETLAND LINE
	LIMIT OF SITE SPECIFIC SOILS SURVEY
	SOIL LINE
	SOIL SERIES
	NRCS SOIL LINE
	NRCS SOIL LABEL
	LIMIT OF WATERSHED
	TIME OF CONCENTRATION PATH
	FLOW REACH
	MATCH LINE
	R.C.R.D. ROCKINGHAM COUNTY REGISTRY OF DEEDS
	TYP. TYPICAL
	FND. FOUND
	TBR. TO BE REMOVED

SYMBOLS LEGEND:

	#	SUBCATCHMENT AREA SYMBOL
	#	FLOW REACH SYMBOL
	#	POND DEVICE SYMBOL
	#	TIME OF CONCENTRATION SEGMENT

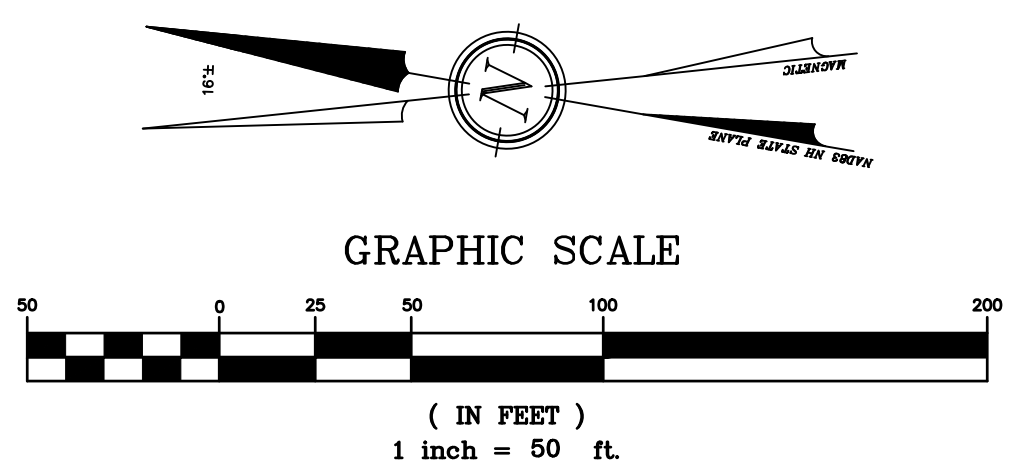

WETLAND NOTE:

WETLANDS WERE DELINEATED BY JOHN P. HAYES, CWS, IN THE SUMMER OF 2022 USING THE FOLLOWING CRITERIA:

1. USACE. REGIONAL SUPPLEMENT TO THE CORPS OF ENGINEERS WETLAND DELINEATION MANUAL: NORTHCENTRAL AND NORTHEAST REGION. VERSION 2.0. U.S. ARMY ENGINEER RESEARCH AND DEVELOPMENT CENTER. 2012. VICKSBURG, MS.
2. USACE. CORPS OF ENGINEERS WETLANDS DELINEATION MANUAL. ENVIRONMENTAL LABORATORY. 1987. VICKSBURG, MS.
3. UNITED STATES DEPARTMENT OF AGRICULTURE, NATURAL RESOURCES CONSERVATION SERVICE. 2018. FIELD INDICATORS OF HYDRIC SOILS IN THE UNITED STATES, VERSION 8.2. L.M. VASILAS, G.W. HURT, AND J.F. BERKOWITZ (EDS.). USDA, NRCS, IN COOPERATION WITH THE NATIONAL TECHNICAL COMMITTEE FOR HYDRIC SOILS.
4. NEW ENGLAND HYDRIC SOIL TECHNICAL COMMITTEE. FIELD INDICATORS FOR IDENTIFYING HYDRIC SOILS IN NEW ENGLAND. VERSION 4. NEW ENGLAND INTERSTATE WATER POLLUTION CONTROL COMMISSION. 2019. LOWELL, MA.
5. U.S. ARMY CORPS OF ENGINEERS 2019. NATIONAL WETLAND PLANT LIST, VERSION 3.3. [HTTP://WETLAND-PLANTS.USACE.ARMY.MIL/](http://wetland-plants.usace.army.mil/)

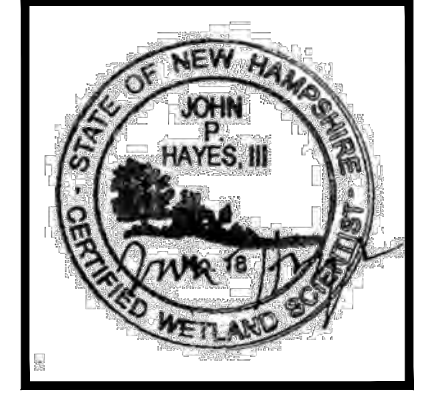

JOHN P. HAYES, CWS

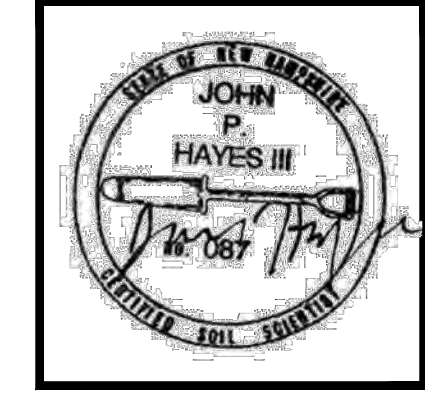

JOHN P. HAYES, CSS

REVISION	DATE	DESCRIPTION

FOR
OWL RIDGE BUILDERS
LAND OF
FREDERICK FERNALD
SMOKE STREET & FORT HILL ROAD
NOTTINGHAM, N.H.
TAX MAP 23, Lot 11

BERRY SURVEYING & ENGINEERING
335 SECOND CROWN POINT ROAD
BARRINGTON, NH 03825 (603)332-2863
SCALE : 1 IN. EQUALS 50 FT.
DATE : FEBRUARY 15, 2023
FILE NO. : DB 2020 - 065

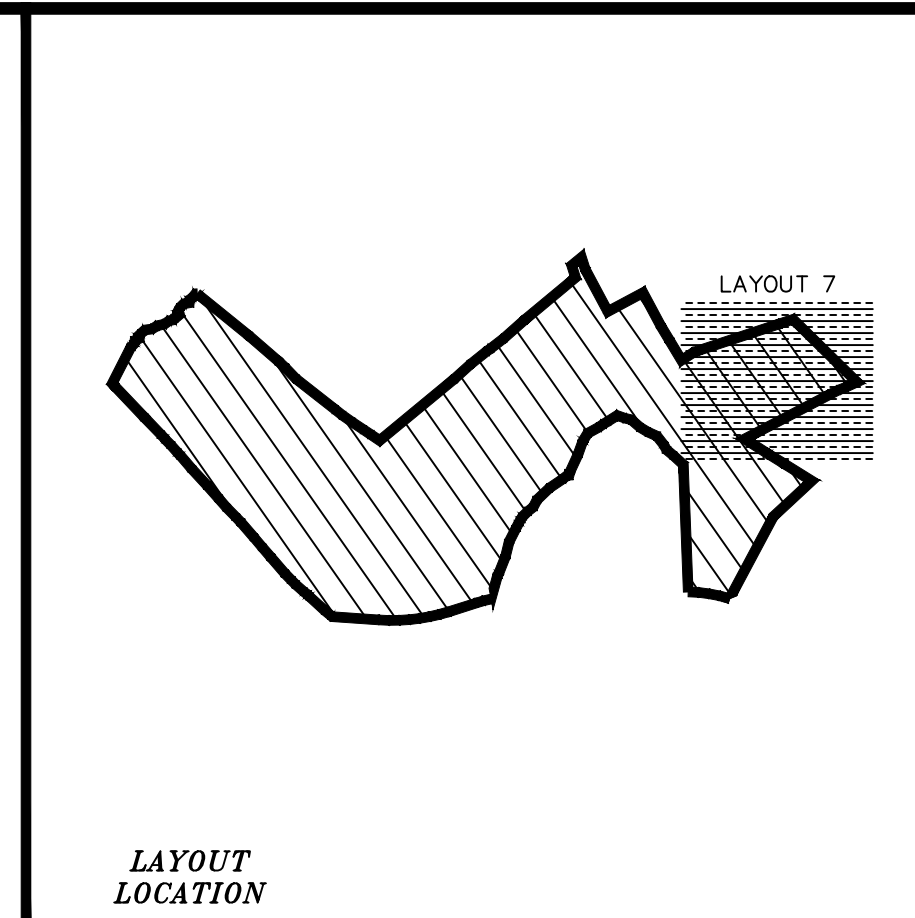
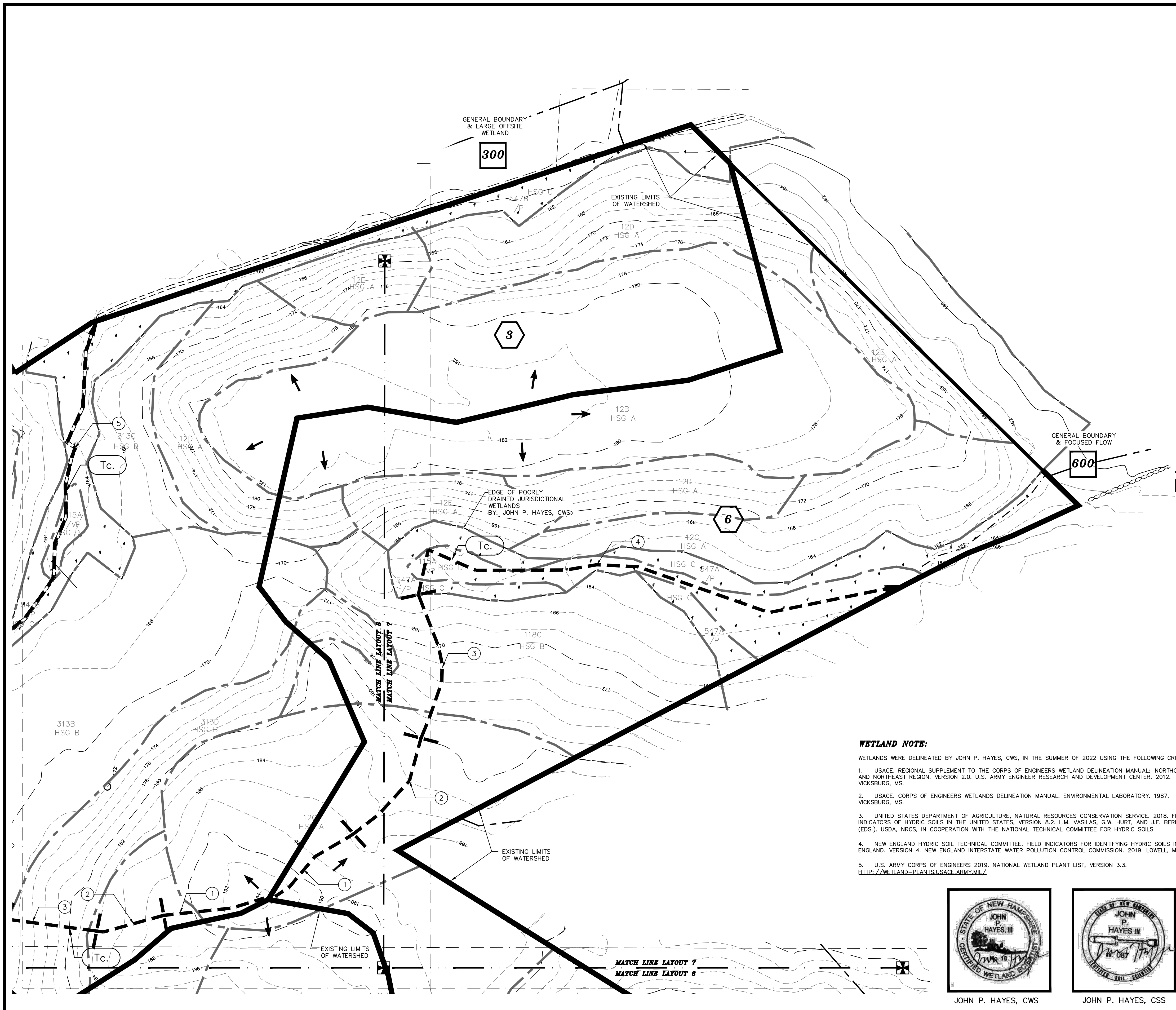

NOTES:

- 1.) OWNER: FREDERICK FERNALD
PO BOX 1805
WOLFEBORO, NH 03894
- 1A.) APPLICANT: OWL RIDGE BUILDERS
104 RAYMOND ROAD
NOTTINGHAM, NH 03290
- 2.) TAX MAP 23, LOT 11
- 3.) LOT AREA: 4,477,048 Sq.Ft., 102.77 Ac.
- 4.) THE INTENT OF THIS PLAN IS TO SHOW THE EXISTING DRAINAGE CONDITIONS OF TAX MAP 23, LOT 11 AS OF THE DATE OF THE SURVEY.
- 5.) HYDROCAD USES A SERIES OF NODE SUFFIXES FOR NUMBERING PURPOSES (S=SUBCATCHMENT, P=POND DEVICE, R=REACH), TO SIMPLIFY ANNOTATION THESE SUFFIXES ARE LEFT OFF THE WATERSHED PLANS AND NODE TYPE IS DENOTED BY THE SYMBOL SHAPE ACCORDING TO THE DISPLAYED LEGEND WHICH COINCIDES WITH HYDROCAD GRAPHICS.

LEGEND:

	EXISTING CONTOUR MINOR
	EXISTING CONTOUR MAJOR
	STONE WALL
	WETLAND LINE
	LIMIT OF SITE SPECIFIC SOILS SURVEY
	SOIL LINE
	448A
	NRCS SOIL LINE
	NRCS SOIL LABEL
	LIMIT OF WATERSHED
	TIME OF CONCENTRATION PATH
	FLOW REACH
	MATCH LINE
	R.C.R.D.
	TYP
	FND
	FOUND
	TBR
	TO BE REMOVED

SYMBOLS LEGEND:

	Subcatchment Area Symbol
	Flow Reach Symbol
	Pond Device Symbol
	Time of Concentration Segment

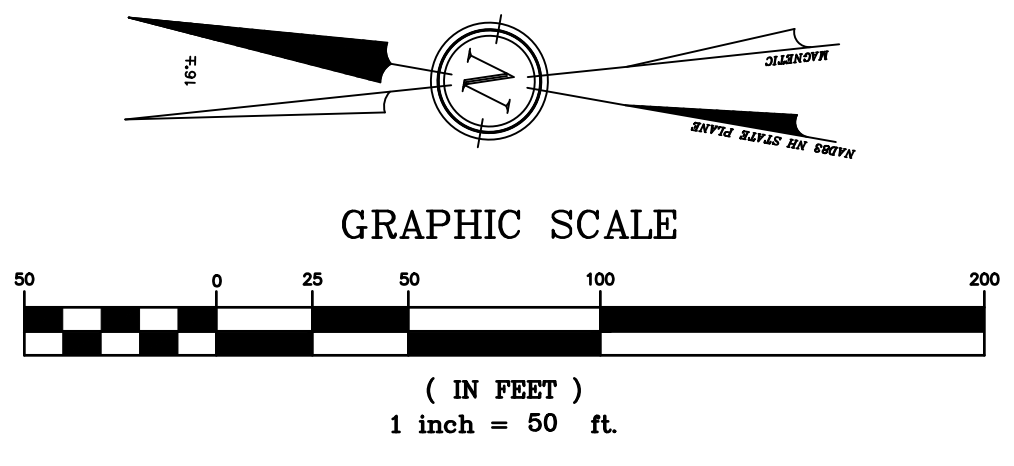

WETLAND NOTE:

WETLANDS WERE DELINEATED BY JOHN P. HAYES, CWS, IN THE SUMMER OF 2022 USING THE FOLLOWING CRITERIA:

1. USACE, REGIONAL SUPPLEMENT TO THE CORPS OF ENGINEERS WETLAND DELINEATION MANUAL: NORTH-CENTRAL AND NORTHEAST REGION, VERSION 2.0. U.S. ARMY ENGINEER RESEARCH AND DEVELOPMENT CENTER, 2012. VICKSBURG, MS.
2. USACE, CORPS OF ENGINEERS WETLANDS DELINEATION MANUAL, ENVIRONMENTAL LABORATORY, 1987. VICKSBURG, MS.
3. UNITED STATES DEPARTMENT OF AGRICULTURE, NATURAL RESOURCES CONSERVATION SERVICE, 2018. FIELD INDICATORS OF HYDRIC SOILS IN THE UNITED STATES, VERSION 8.2. L.M. VASILAS, G.W. HURT, AND J.F. BERKOWITZ (EDS.). USDA, NRCS, IN COOPERATION WITH THE NATIONAL TECHNICAL COMMITTEE FOR HYDRIC SOILS.
4. NEW ENGLAND HYDRIC SOIL TECHNICAL COMMITTEE, FIELD INDICATORS FOR IDENTIFYING HYDRIC SOILS IN NEW ENGLAND, VERSION 4, NEW ENGLAND INTERSTATE WATER POLLUTION CONTROL COMMISSION, 2019. LOWELL, MA.
5. U.S. ARMY CORPS OF ENGINEERS 2019, NATIONAL WETLAND PLANT LIST, VERSION 3.3. [HTTP://WETLAND-PLANTS.USACE.ARMY.MIL/](http://wetland-plants.usace.army.mil/)

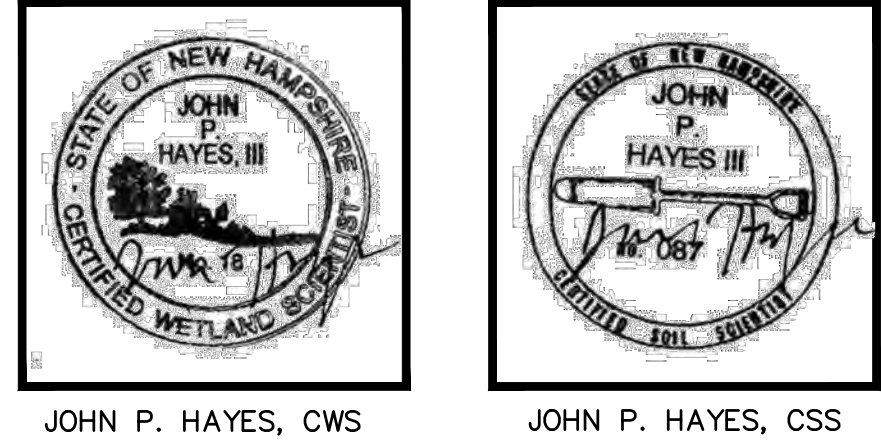

REVISION	DATE	DESCRIPTION

FOR
 OWL RIDGE BUILDERS
 LAND OF
 FREDERICK FERNALD
 SMOKE STREET & FORT HILL ROAD
 NOTTINGHAM, N.H.
 TAX MAP 23, LOT 11

W-1 EXISTING CONDITIONS WATERSHED PLAN - LAYOUT 7

BERRY SURVEYING & ENGINEERING
 335 SECOND CROWN POINT ROAD
 BARRINGTON, NH 03825 (603)332-2863
 SCALE : 1 IN. EQUALS 50 FT.
 DATE : FEBRUARY 15, 2023
 FILE NO. : DB 2020 - 065

SHEET 8 OF 22

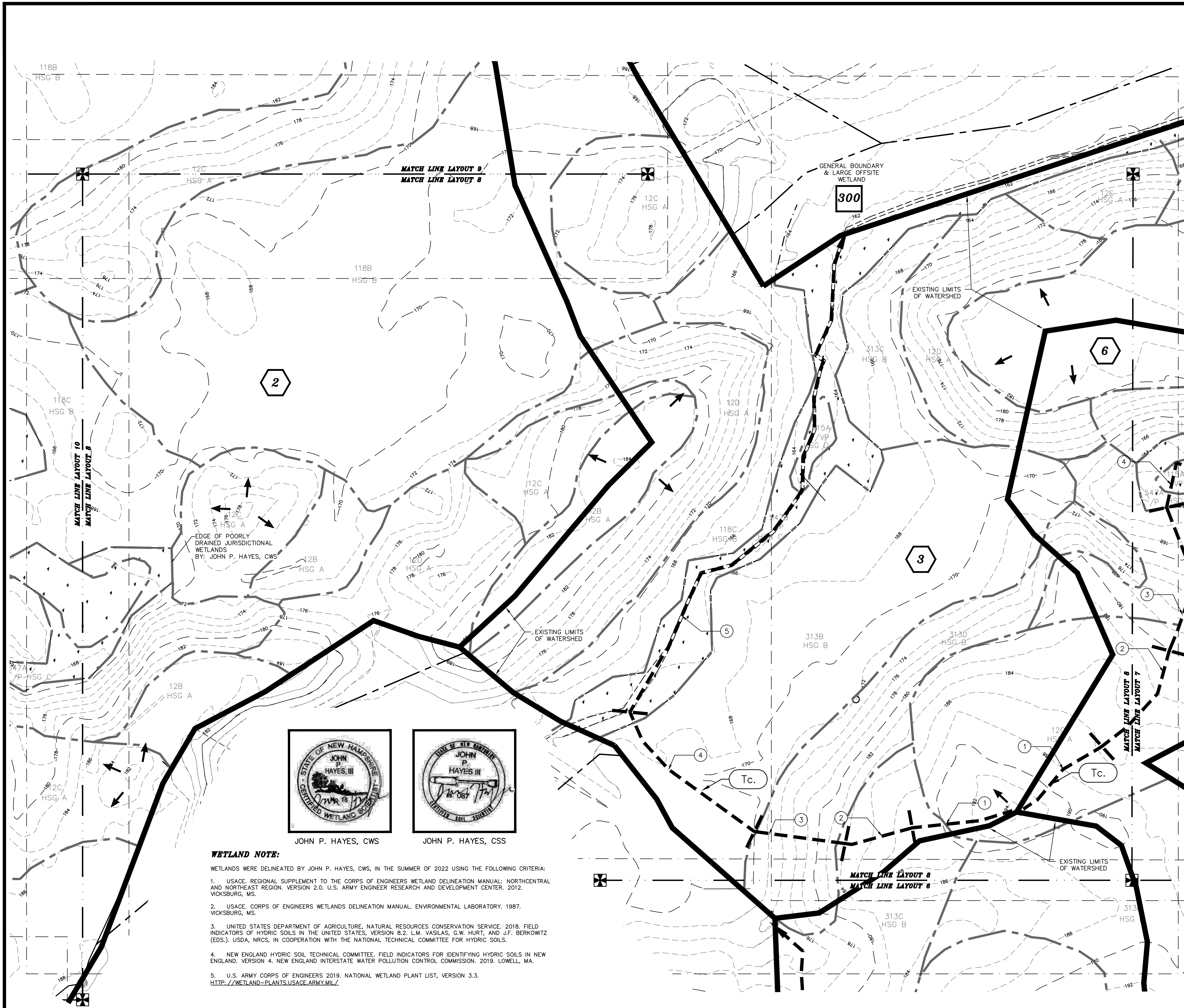

JOHN P. HAYES, CWS

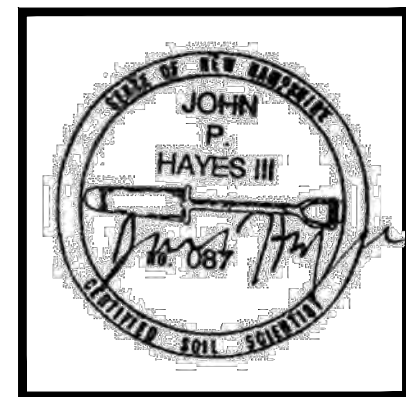

JOHN P. HAYES, CSS

WETLAND NOTE:

- WETLANDS WERE DELINEATED BY JOHN P. HAYES, CWS, IN THE SUMMER OF 2022 USING THE FOLLOWING CRITERIA:
- USACE, REGIONAL SUPPLEMENT TO THE CORPS OF ENGINEERS WETLAND DELINEATION MANUAL: NORTHCENTRAL AND NORTHEAST REGION, VERSION 2.0, U.S. ARMY ENGINEER RESEARCH AND DEVELOPMENT CENTER, 2012, VICKSBURG, MS.
 - USACE, CORPS OF ENGINEERS WETLANDS DELINEATION MANUAL, ENVIRONMENTAL LABORATORY, 1987, VICKSBURG, MS.
 - UNITED STATES DEPARTMENT OF AGRICULTURE, NATURAL RESOURCES CONSERVATION SERVICE, 2018, FIELD INDICATORS OF HYDRIC SOILS IN THE UNITED STATES, VERSION 8.2, L.M. VASILAS, G.W. HURT, AND J.F. BERKOWITZ (EDS.), USDA, NRCS, IN COOPERATION WITH THE NATIONAL TECHNICAL COMMITTEE FOR HYDRIC SOILS.
 - NEW ENGLAND HYDRIC SOIL TECHNICAL COMMITTEE, FIELD INDICATORS FOR IDENTIFYING HYDRIC SOILS IN NEW ENGLAND, VERSION 4, NEW ENGLAND INTERSTATE WATER POLLUTION CONTROL COMMISSION, 2019, LOWELL, MA.
 - U.S. ARMY CORPS OF ENGINEERS 2019, NATIONAL WETLAND PLANT LIST, VERSION 3.3. [HTTP://WETLAND-PLANTS.USACE.ARMY.MIL/](http://wetland-plants.usace.army.mil/)

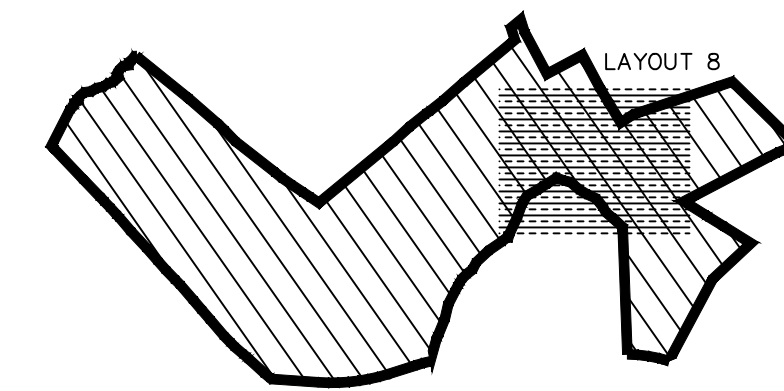

LAYOUT LOCATION

NOTES:

- OWNER: FREDERICK FERNALD
PO BOX 1805
WOLFEBORO, NH 03894
- APPLICANT: OWL RIDGE BUILDERS
104 RAYMOND ROAD
NOTTINGHAM, NH 03290
- TAX MAP 23, LOT 11
- LOT AREA: 4,477,048 Sq.Ft., 102.77 Ac.
- THE INTENT OF THIS PLAN IS TO SHOW THE EXISTING DRAINAGE CONDITIONS OF TAX MAP 23, LOT 11 AS OF THE DATE OF THE SURVEY.
- HYDROCAD USES A SERIES OF NODE SUFFIXES FOR NUMBERING PURPOSES (S=SUBCATCHMENT, P=POND DEVICE, R=REACH), TO SIMPLIFY ANNOTATION THESE SUFFIXES ARE LEFT OFF THE WATERSHED PLANS AND NODE TYPE IS DENOTED BY THE SYMBOL SHAPE ACCORDING TO THE DISPLAYED LEGEND WHICH COINCIDES WITH HYDROCAD GRAPHICS.

LEGEND:

- EXISTING CONTOUR MINOR
- EXISTING CONTOUR MAJOR
- STONE WALL
- WETLAND LINE
- LIMIT OF SITE SPECIFIC SOILS SURVEY
- SOIL SERIES 448A
- NRCS SOIL LINE HFB
- NRCS SOIL LABEL
- LIMIT OF WATERSHED
- TIME OF CONCENTRATION PATH
- FLOW REACH
- MATCH LINE
- R.C.R.D. ROCKINGHAM COUNTY REGISTRY OF DEEDS
- TYP. TYPICAL
- FND. FOUND
- TBR. TO BE REMOVED

SYMBOLS LEGEND:

- SUBCATCHMENT AREA SYMBOL
- FLOW REACH SYMBOL
- POND DEVICE SYMBOL
- TIME OF CONCENTRATION SEGMENT

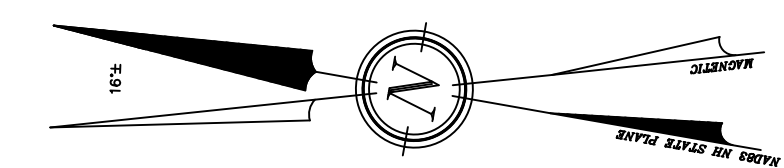

GRAPHIC SCALE

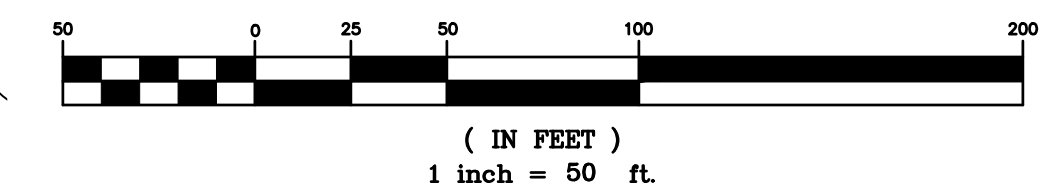

W-1 EXISTING CONDITIONS WATERSHED PLAN - LAYOUT 8

FOR
OWL RIDGE BUILDERS
LAND OF
FREDERICK FERNALD
SMOKE STREET & FORT HILL ROAD
NOTTINGHAM, N.H.
TAX MAP 23, Lot 11

BERRY SURVEYING & ENGINEERING
335 SECOND CROWN POINT ROAD
BARRINGTON, NH 03825 (603)332-2863
SCALE : 1 IN. EQUALS 50 FT.
DATE : FEBRUARY 15, 2023
FILE NO. : DB 2020 - 065

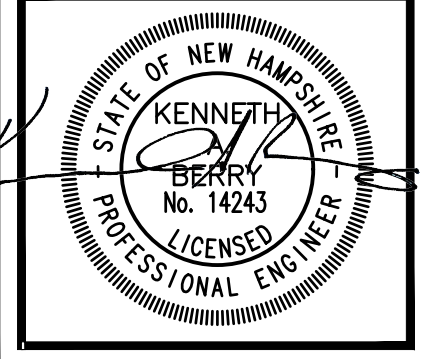

WETLAND NOTE:

- WETLANDS WERE DELINEATED BY JOHN P. HAYES, CWS, IN THE SUMMER OF 2022 USING THE FOLLOWING CRITERIA:
1. USACE, REGIONAL SUPPLEMENT TO THE CORPS OF ENGINEERS WETLAND DELINEATION MANUAL: NORTH-CENTRAL AND NORTHEAST REGION, VERSION 2.0. U.S. ARMY ENGINEER RESEARCH AND DEVELOPMENT CENTER, 2012. VICKSBURG, MS.
 2. USACE, CORPS OF ENGINEERS WETLANDS DELINEATION MANUAL, ENVIRONMENTAL LABORATORY, 1987. VICKSBURG, MS.
 3. UNITED STATES DEPARTMENT OF AGRICULTURE, NATURAL RESOURCES CONSERVATION SERVICE, 2018. FIELD INDICATORS OF HYDRIC SOILS IN THE UNITED STATES, VERSION 8.2. L.M. VASILAS, G.W. HURT, AND J.F. BERKOWITZ (EDS.). USDA, NRCS, IN COOPERATION WITH THE NATIONAL TECHNICAL COMMITTEE FOR HYDRIC SOILS.
 4. NEW ENGLAND HYDRIC SOIL TECHNICAL COMMITTEE, FIELD INDICATORS FOR IDENTIFYING HYDRIC SOILS IN NEW ENGLAND, VERSION 4. NEW ENGLAND INTERSTATE WATER POLLUTION CONTROL COMMISSION, 2019. LOWELL, MA.
 5. U.S. ARMY CORPS OF ENGINEERS 2019, NATIONAL WETLAND PLANT LIST, VERSION 3.3. [HTTP://WETLAND-PLANTS.USACE.ARMY.MIL/](http://wetland-plants.usace.army.mil/)

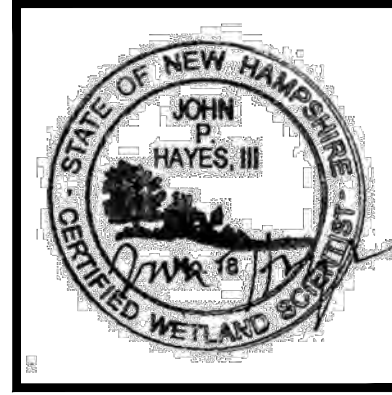

JOHN P. HAYES, CWS

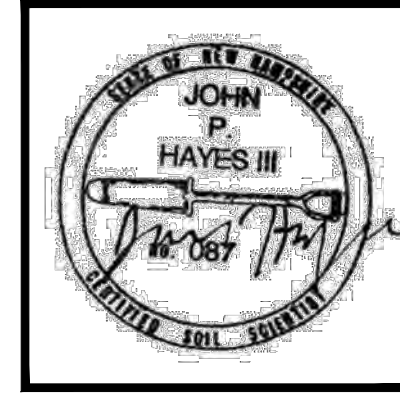

JOHN P. HAYES, CSS

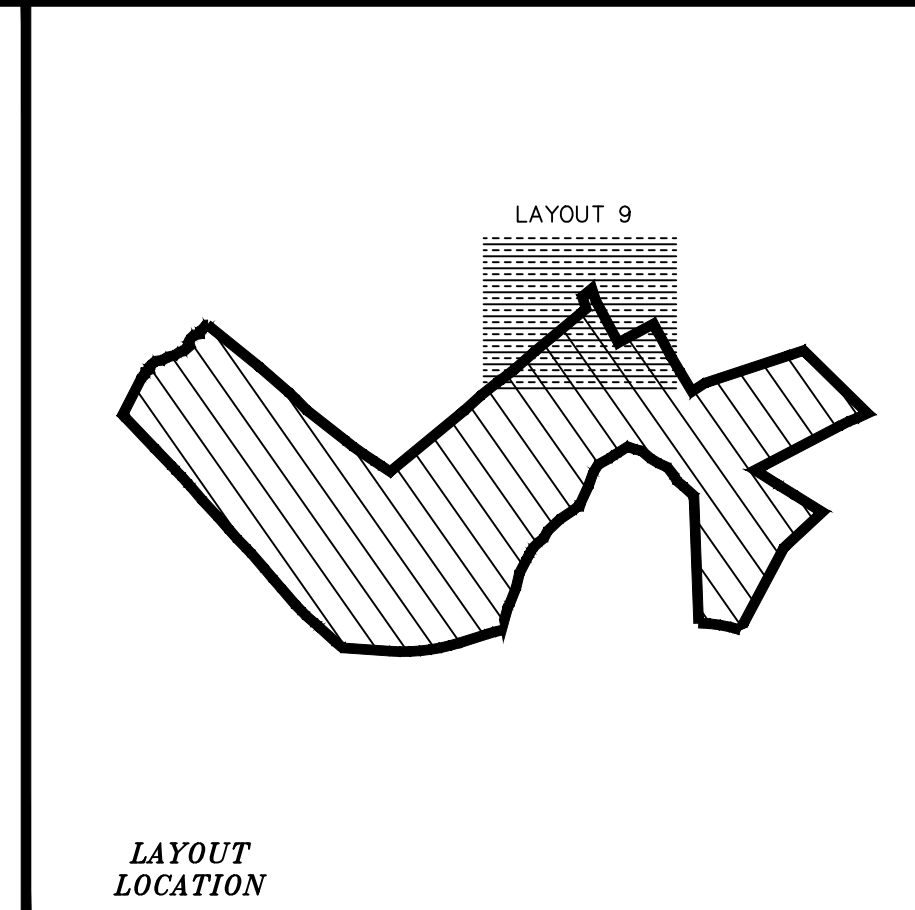

NOTES:

- 1.) OWNER: FREDERICK FERNALD
PO BOX 1805
WOLFEBORO, NH 03894
- 1A.) APPLICANT: OWL RIDGE BUILDERS
104 RAYMOND ROAD
NOTTINGHAM, NH 03290
- 2.) TAX MAP 23, LOT 11
- 3.) LOT AREA: 4,477,048 Sq.Ft., 102.77 Ac.
- 4.) THE INTENT OF THIS PLAN IS TO SHOW THE EXISTING DRAINAGE CONDITIONS OF TAX MAP 23, LOT 11 AS OF THE DATE OF THE SURVEY.
- 5.) HYDROCAD USES A SERIES OF NODE SUFFIXES FOR NUMBERING PURPOSES (S=SUBCATCHMENT, P=POND DEVICE, R=REACH), TO SIMPLIFY ANNOTATION THESE SUFFIXES ARE LEFT OFF THE WATERSHED PLANS AND NODE TYPE IS DENOTED BY THE SYMBOL SHAPE ACCORDING TO THE DISPLAYED LEGEND WHICH COINCIDES WITH HYDROCAD GRAPHICS.

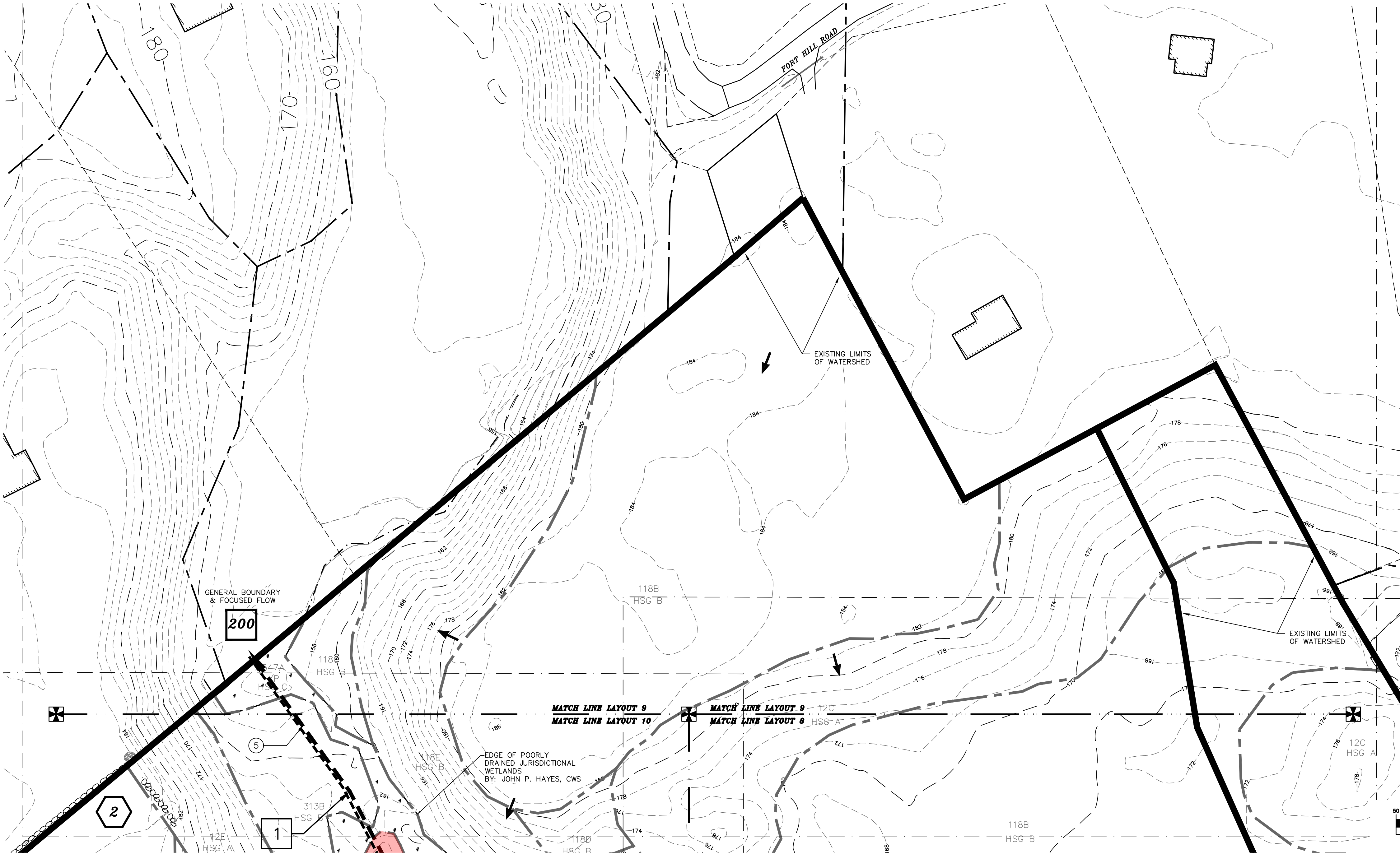

LEGEND:

	EXISTING CONTOUR MINOR
	EXISTING CONTOUR MAJOR
	STONE WALL
	WETLAND LINE
	LIMIT OF SITE SPECIFIC SOILS SURVEY
	SOIL LINE
	448A SOIL SERIES
	NRCS SOIL LINE
	NRCS SOIL LABEL
	HFB NRCS SOIL LABEL
	LIMIT OF WATERSHED
	TIME OF CONCENTRATION PATH
	FLOW REACH
	MATCH LINE
	ROCKINGHAM COUNTY REGISTRY OF DEEDS
	R.C.R.D.
	TYP. TYPICAL
	FND FOUND
	TBR TO BE REMOVED

SYMBOLS LEGEND:

	Subcatchment Area Symbol
	Flow Reach Symbol
	Pond Device Symbol
	Time of Concentration Segment

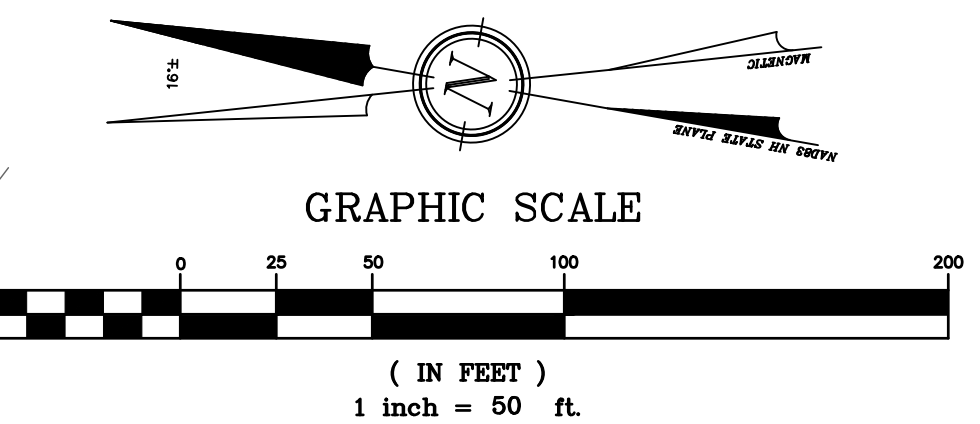

REVISION	DATE	DESCRIPTION

FOR
OWL RIDGE BUILDERS
LAND OF
FREDERICK FERNALD
SMOKE STREET & FORT HILL ROAD
NOTTINGHAM, N.H.
TAX MAP 23, Lot 11

BERRY SURVEYING & ENGINEERING
335 SECOND CROWN POINT ROAD
BARRINGTON, NH 03825 (603)332-2863
SCALE : 1 IN. EQUALS 50 FT.
DATE : FEBRUARY 15, 2023
FILE NO. : DB 2020 - 065

WETLAND NOTE:

WETLANDS WERE DELINEATED BY JOHN P. HAYES, CWS, IN THE SUMMER OF 2022 USING THE FOLLOWING CRITERIA:

1. USACE, REGIONAL SUPPLEMENT TO THE CORPS OF ENGINEERS WETLAND DELINEATION MANUAL: NORTHCENTRAL AND NORTHEAST REGION, VERSION 2.0. U.S. ARMY ENGINEER RESEARCH AND DEVELOPMENT CENTER, 2012. WICKSBURG, MS.
2. USACE, CORPS OF ENGINEERS WETLANDS DELINEATION MANUAL, ENVIRONMENTAL LABORATORY, 1987. WICKSBURG, MS.
3. UNITED STATES DEPARTMENT OF AGRICULTURE, NATURAL RESOURCES CONSERVATION SERVICE, 2018. FIELD INDICATORS OF HYDRIC SOILS IN THE UNITED STATES, VERSION 8.2. L.M. VASILAS, G.W. HURT, AND J.F. BERKOWITZ (EDS.), USDA, NRCS, IN COOPERATION WITH THE NATIONAL TECHNICAL COMMITTEE FOR HYDRIC SOILS.
4. NEW ENGLAND HYDRIC SOIL TECHNICAL COMMITTEE, FIELD INDICATORS FOR IDENTIFYING HYDRIC SOILS IN NEW ENGLAND, VERSION 4. NEW ENGLAND INTERSTATE WATER POLLUTION CONTROL COMMISSION, 2019. LOWELL, MA.
5. U.S. ARMY CORPS OF ENGINEERS 2019, NATIONAL WETLAND PLANT LIST, VERSION 3.3. [HTTP://WETLAND-PLANTS.USACE.ARMY.MIL/](http://wetland-plants.usace.army.mil/)



JOHN P. HAYES, CWS

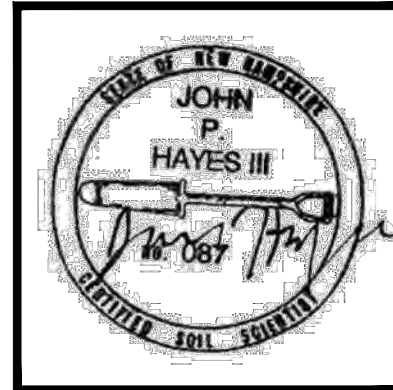

JOHN P. HAYES, CSS

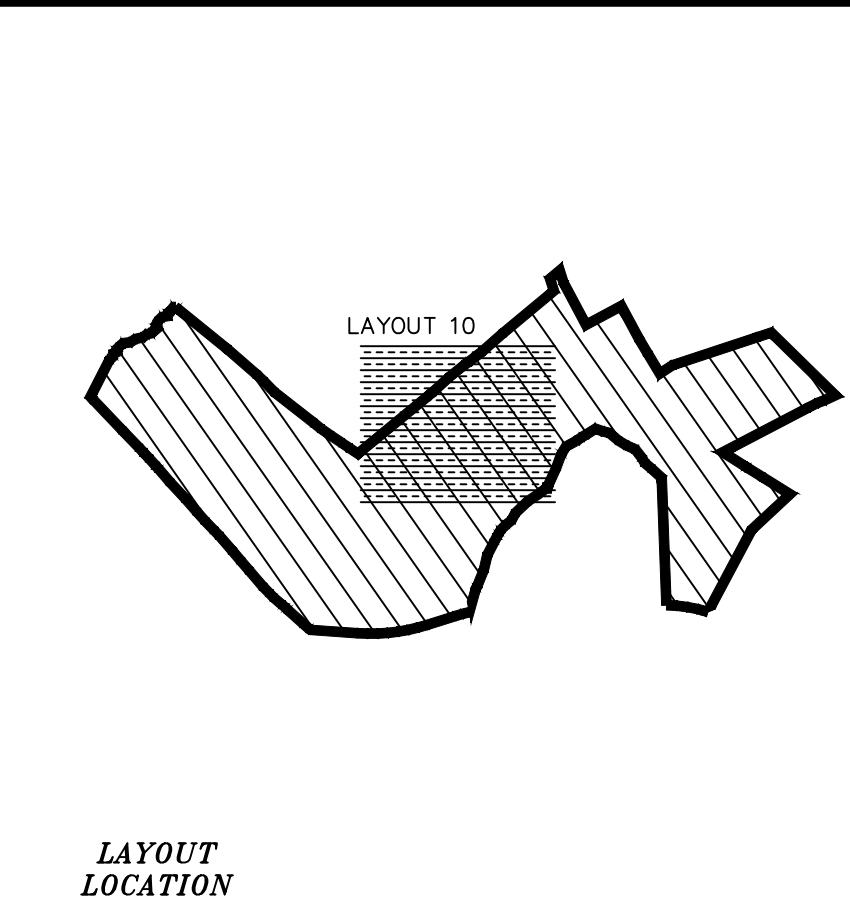
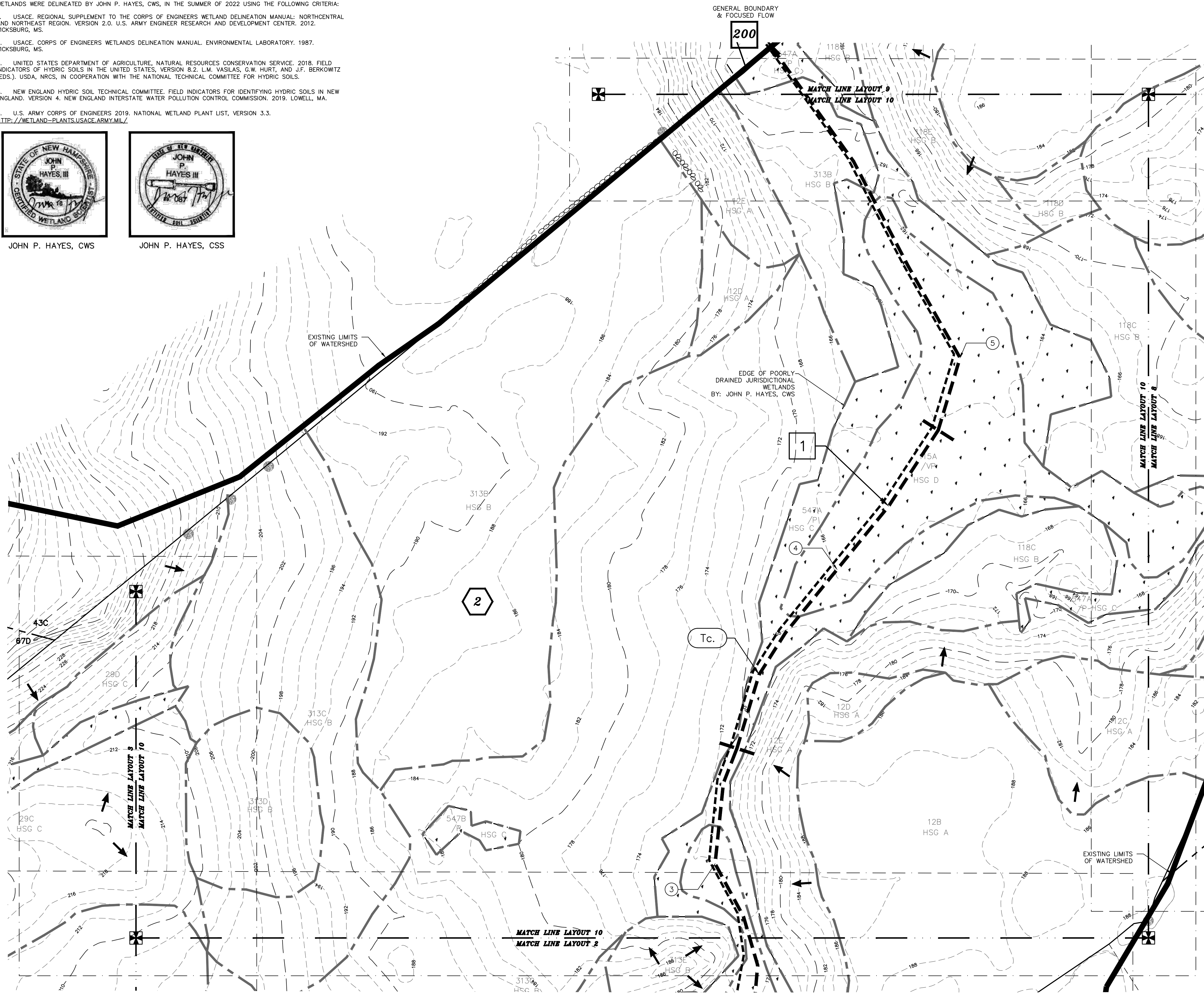

- NOTES:**
- 1.) OWNER: FREDERICK FERNALD
PO BOX 1805
WOLFEBORO, NH 03894
 - 1A.) APPLICANT: OWL RIDGE BUILDERS
104 RAYMOND ROAD
NOTTINGHAM, NH 03290
 - 2.) TAX MAP 23, LOT 11
 - 3.) LOT AREA: 4,477,048 Sq.Ft., 102.77 Ac.
 - 4.) THE INTENT OF THIS PLAN IS TO SHOW THE EXISTING DRAINAGE CONDITIONS OF TAX MAP 23, LOT 11 AS OF THE DATE OF THE SURVEY.
 - 5.) HYDROCAD USES A SERIES OF NODE SUFFIXES FOR NUMBERING PURPOSES (S=SUBCATCHMENT, P=POND DEVICE, R=REACH), TO SIMPLIFY ANNOTATION THESE SUFFIXES ARE LEFT OFF THE WATERSHED PLANS AND NODE TYPE IS DENOTED BY THE SYMBOL SHAPE ACCORDING TO THE DISPLAYED LEGEND WHICH COINCIDES WITH HYDROCAD GRAPHICS.

LEGEND:

	EXISTING CONTOUR MINOR
	EXISTING CONTOUR MAJOR
	STONE WALL
	WETLAND LINE
	LIMIT OF SITE SPECIFIC SOILS SURVEY
	SOIL LINE
	448A SOIL SERIES
	NRCS SOIL LINE
	NRCS SOIL LABEL
	LIMIT OF WATERSHED
	TIME OF CONCENTRATION PATH
	FLOW REACH
	MATCH LINE
	R.C.R.D. ROCKINGHAM COUNTY REGISTRY OF DEEDS
	TYP. TYPICAL
	FND FOUND
	TBR TO BE REMOVED

SYMBOLS LEGEND:

	#	SUBCATCHMENT AREA SYMBOL
	#	FLOW REACH SYMBOL
	#	POND DEVICE SYMBOL
	#	TIME OF CONCENTRATION SEGMENT

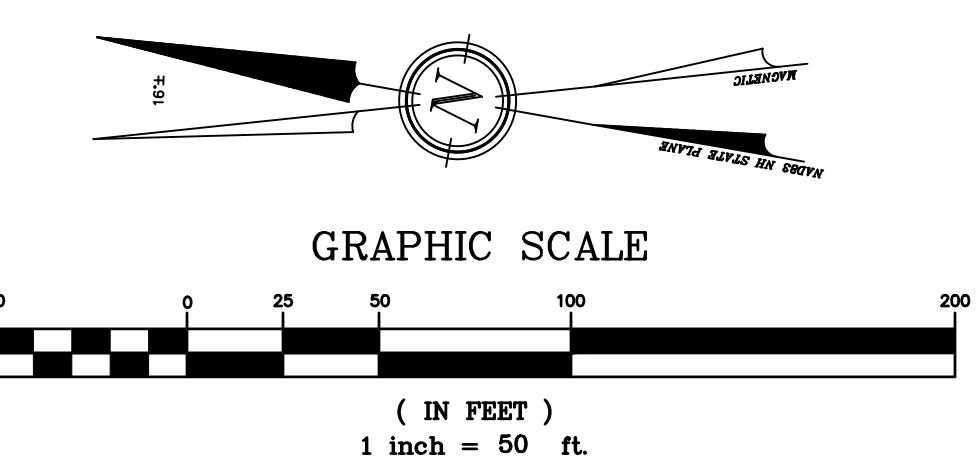

W-1 EXISTING CONDITIONS WATERSHED PLAN - LAYOUT 10

REVISION	DATE	DESCRIPTION

FOR
OWL RIDGE BUILDERS
LAND OF
FREDERICK FERNALD
SMOKE STREET & FORT HILL ROAD
NOTTINGHAM, N.H.
TAX MAP 23, Lot 11

BERRY SURVEYING & ENGINEERING
335 SECOND CROWN POINT ROAD
BARRINGTON, NH 03825 (603)332-2863
SCALE : 1 IN. EQUALS 50 FT.
DATE : FEBRUARY 15, 2023
FILE NO. : DB 2020 - 065

SHEET 11 OF 22